

**POINT AUTOFOCUS PROBE**

(ISO 25178-605)

**POINT AUTOFOCUS PROBE  
SURFACE TEXTURE MEASURING INSTRUMENT  
PF-60**



*Faster  
Easier  
More precise*

**Mitaka**

# Measure large areas quickly

## Large measuring area / high precision measurement

The laser probe with a radius of 0.5 $\mu$ m and the precision XY stage directly measure an area of several tens of millimeters down to the sub-micrometer level (measuring range: XYZ=60mm X 60mm X 10mm, scale resolution: XY=0.1 $\mu$ m, Z=0.01 $\mu$ m)

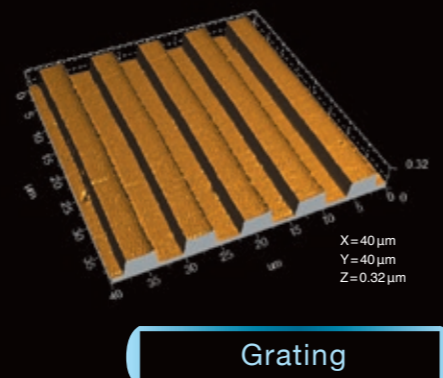
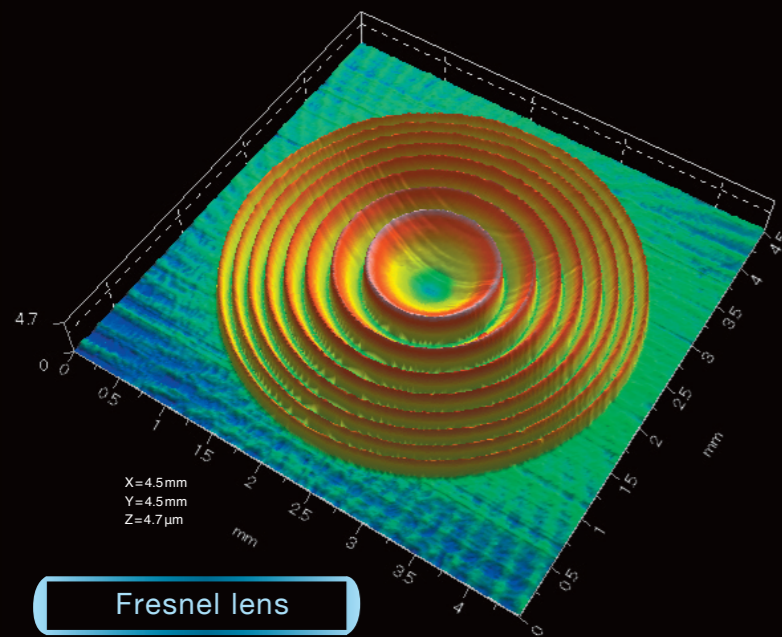

# Higher precision / easier operation

## Excellent angle tracking capability

The highly sensitive autofocus sensor captures low levels of light reflected from the surface of the sample and directly measures steep angles and step heights.

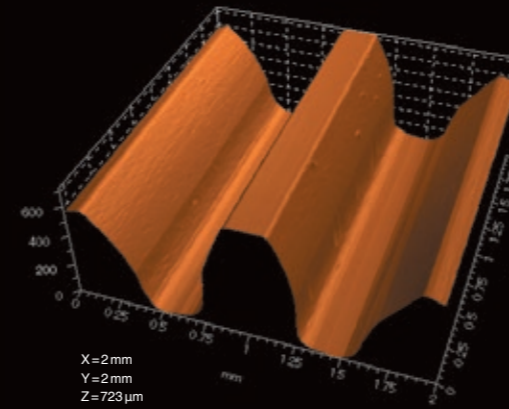

Small diameter gear  
(module: 0.3)

Maximum measurable angle : 87 degrees

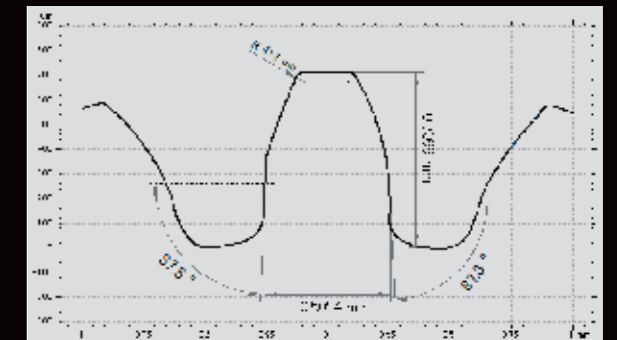

## Fast 3D measurement

**1 hour 20 minutes**  
(conventional instruments)  $\rightarrow$  **6 minutes per 128000 points**

Fast scanning autofocus (AF) function provides large measuring area and high precision measurement

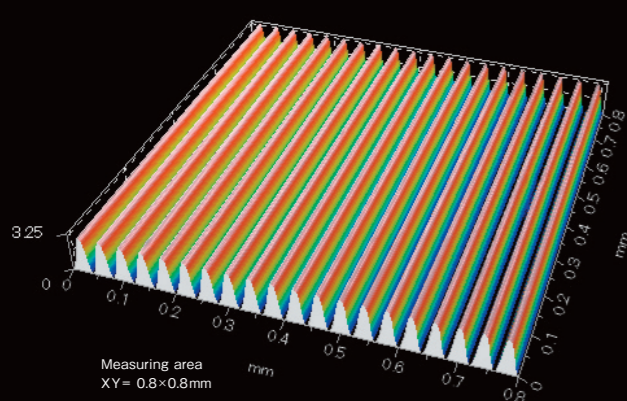

Sinusoidal roughness  
NIST certified SRM2074 calibration standard

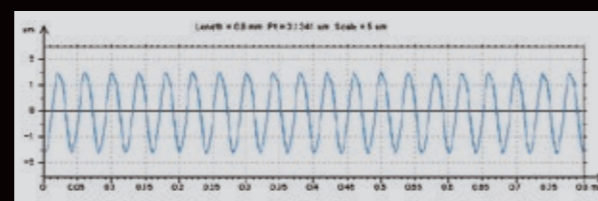
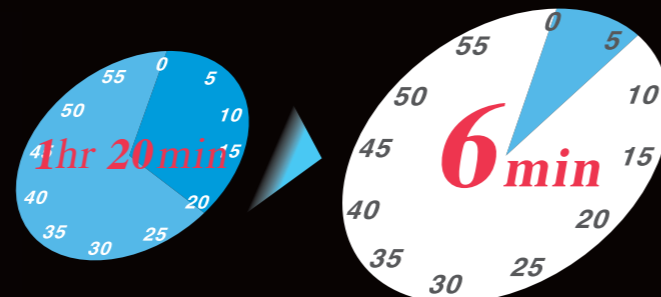

2D measurement: measuring time is only 15 sec. / 8000 points

## Measure visually!

High precision measurement with easy operations

The objective changer (with a slide mechanism) switches between a low power objective for observation and a high power objective for measurement in a single step operation



Monitor the sample while measuring

<p>Wide-field observation</p> <p><b>5X objective</b></p> <ul style="list-style-type: none"> <li>field of view (3.2x2.4mm)</li> <li>sample: microencoder</li> </ul>	<p>Positioning of the measuring point</p> <p><b>100X objective</b></p> <ul style="list-style-type: none"> <li>field of view (0.16x0.12mm)</li> <li>measuring spot: alignment mark</li> </ul>	<p><b>3D measurement</b></p> <ul style="list-style-type: none"> <li>measuring area: XY = 160x120 <math>\mu</math>m</li> <li>measuring pitch: X = 1 <math>\mu</math>m, Y = 1 <math>\mu</math>m</li> </ul>
--	--	--

# ISO approved Mitaka measuring method

We proposed our measuring principle to the International Standards Organization (ISO) as a non-contact measuring method. Our principle has been included in ISO 25178-6:2010 - Classification of methods for areal surface texture - under the name "Point Autofocus Profiling" (ISO 25178-605: Point autofocus probe).

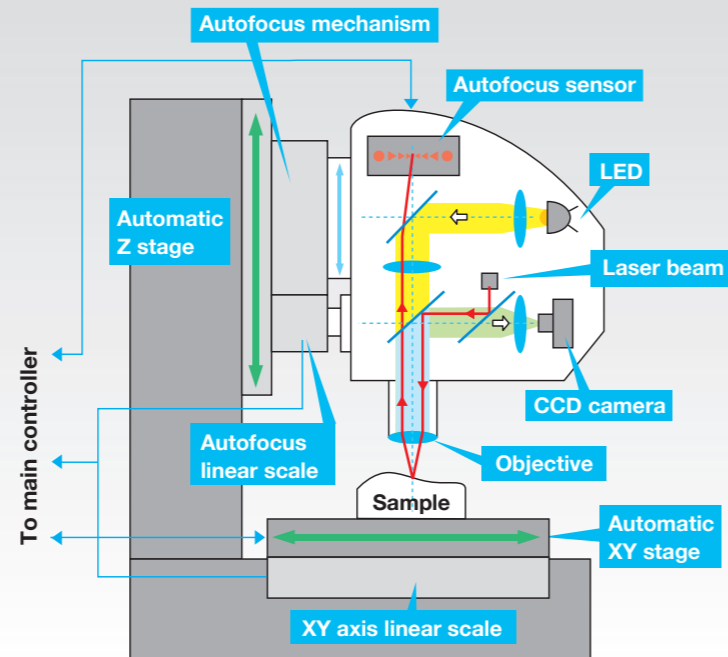

## Measuring principle

### Overview

The PF-60 consists of an autofocus laser beam microscope (AF microscope) and a high precision XY scanning stage. The AF microscope measures height in the Z axis and the XY stage moves the sample in order to obtain XYZ coordinate values for 2D and 3D measurements.

### Scanning XY stage

The PF-60 drives the high-precision XY stage to obtain the coordinate values in its full range of movement (60mm x 60mm). There is no need to stitch measured data since the PF-60 has no measuring limits (such as a restricted field of view) and hence provides high precision measurement of a large area.

### High correlation with the international standards for roughness measurement

Point autofocus profiling (PAP) has a high correlation with roughness standard materials for stylus instruments and obtains reliable data.

<ul style="list-style-type: none"> <li>Roughness standard: TypeD1 (ISO5436-1)</li> <li>Calibration: PTB (Germany)</li> <li>Measurement method: stylus</li> </ul>	<ul style="list-style-type: none"> <li>Tip radius: 5µm</li> <li>Measured length (ln): 4mm</li> <li>Cutoff value(λc): 0.8mm</li> </ul>
--	---

(Stylus: tip radius R=5µm)

Roughness parameters	PTB
Ra	0.227µm(±3%)
Rz	1.50µm(±4%)

PTB inspection result

Roughness parameters	PF-60
Ra	0.228µm
Rz	1.56µm

PF-60 measurement  
(PAP: laser spot radius R=0.5µm)

### Point autofocus probe

The laser beam incorporated in the AF microscope passes through the objective (indicated by the red line in the above diagram) and forms a laser spot on the surface of the sample as a "probe" with a radius of 0.5µm. The reflected laser beam from the sample surface passes through the objective again and forms an image on the autofocus sensor (AF sensor). The AF sensor detects the laser spot displacement in real time and adjusts the AF microscope back to the in-focus position (the laser spot forms its image at the center of the AF sensor).

### Autofocus optical system cuts ghost and stray light

The autofocus optical system cuts out unnecessary light to achieve targeted measurement.

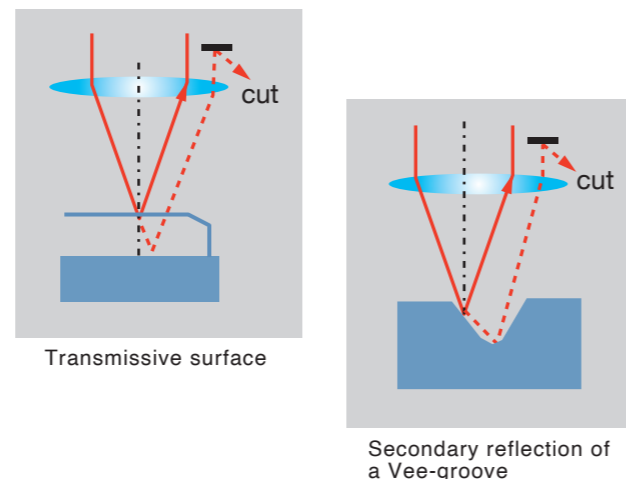

# Surface texture measuring functions

## 2D roughness & contour

Ra=0.104, Sm=10(µm) Roughness standard (Rubert)  
Measured data: Ra=0.101, Sm=10(µm)  
Scanning speed: 300µm/S

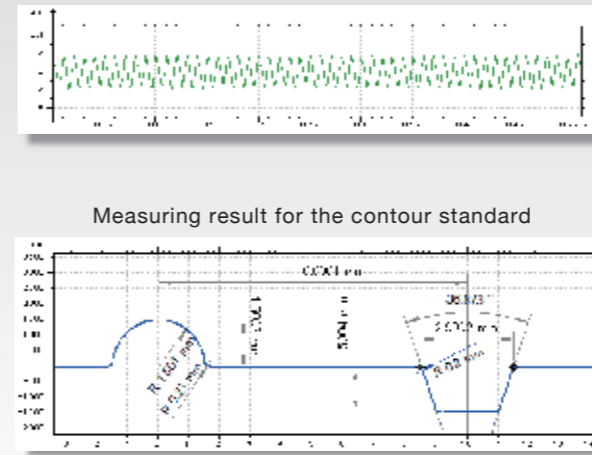

## Surface topography & areal roughness

Areal roughness of the sealed part

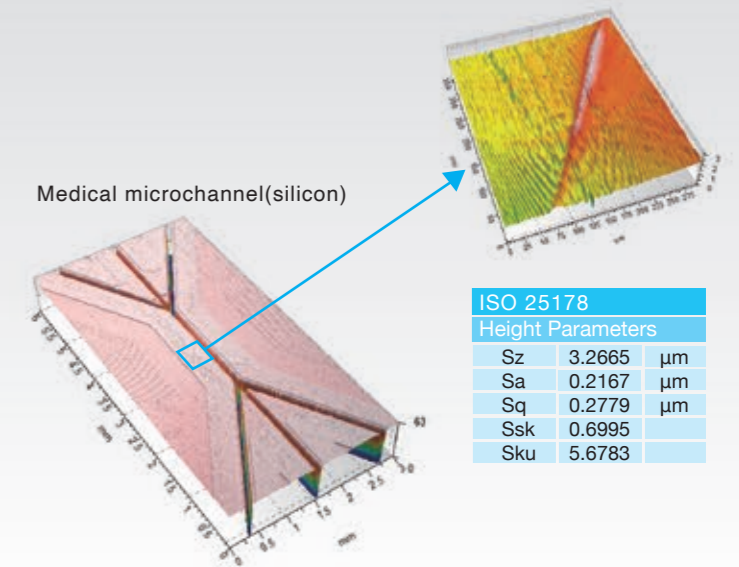

## Various auxiliary functions

### Image capture

The image capture function displays the scale and saves images within the measuring software environment. It facilitates positioning over the measuring area, makes it possible to observe the sample surface during measurement, and provides size measurement within the field of view.

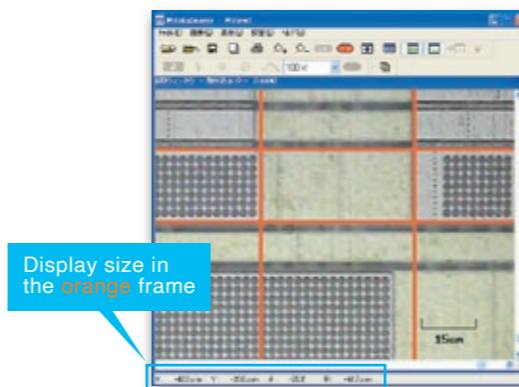

### Temperature correction software

This software ensures that, even when the PF-60 is installed in a non-temperature-controlled room, it maintains measuring accuracy at the sub-micrometer level.

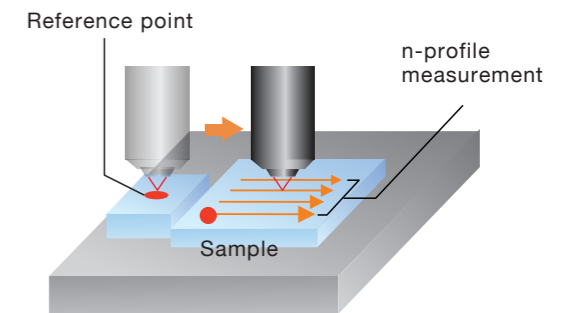

### Mask measurement

Mask measurement provides three types of 3D measurement: inner circle measurement, outer circle measurement and doughnut measurement.

This function reduces total measuring and assessment time by selecting a restricted measuring area.

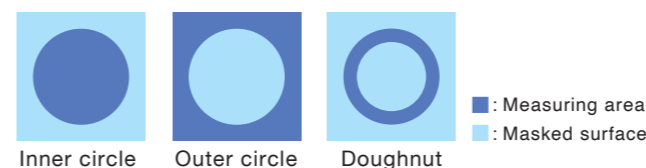

### Patching

Patching increases vertical range virtually by combining sets of 3D data that are measured at different heights with respect to the same XY stage coordinate system.

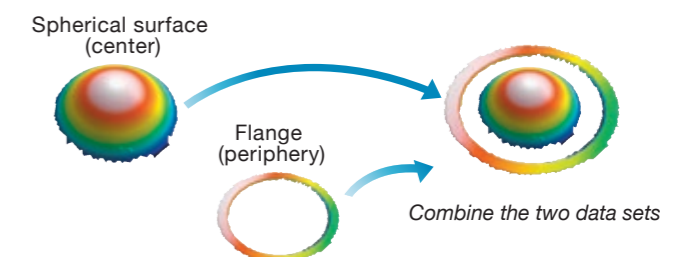

# Surface Texture Measurement comes in 3D

# Perfect solution for measuring all kinds of surface topography

Microlens arrays (optical component)

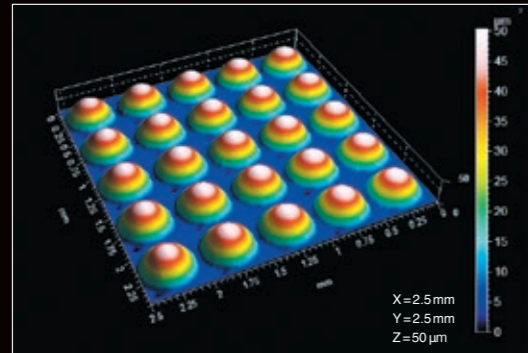

Surface defect of a LED lens (optical component)

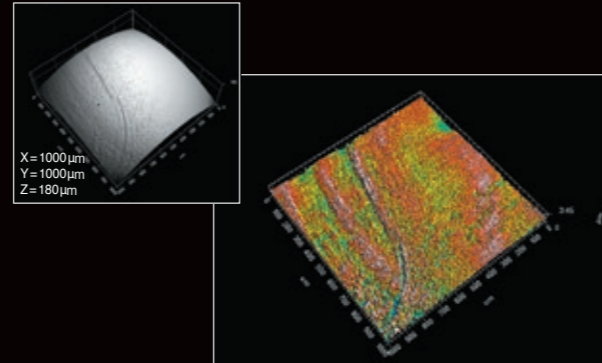

High-density mounting board (electronic component)

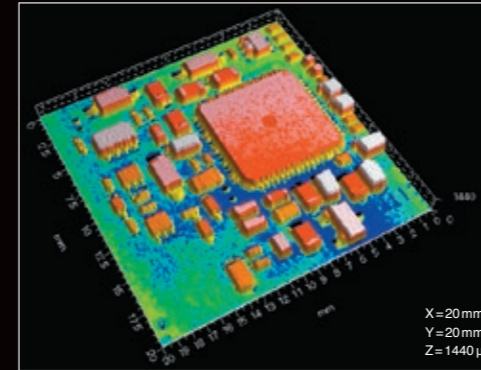

BGA (semiconductor)

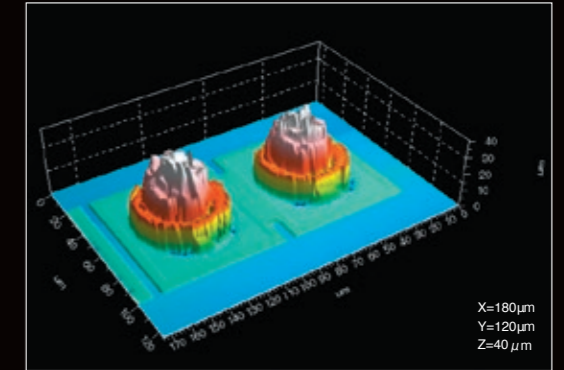

Precision molding die

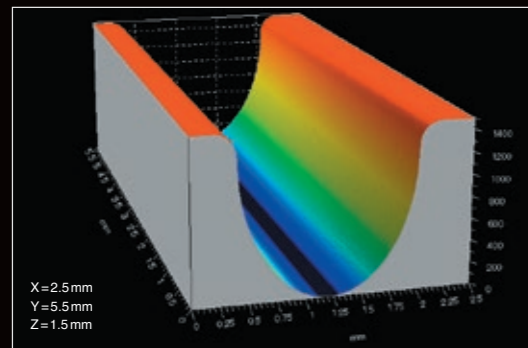

Tip of a turning tool

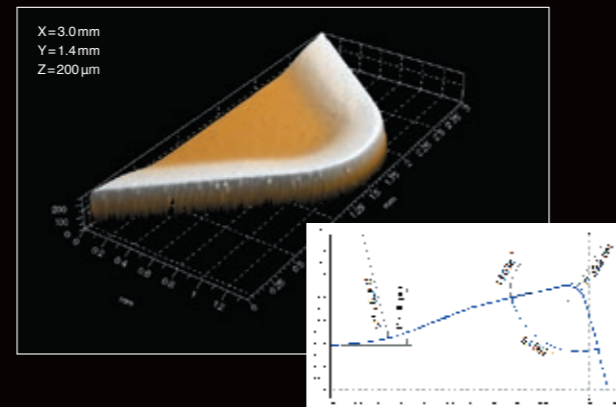

Microencoder (MEMS)

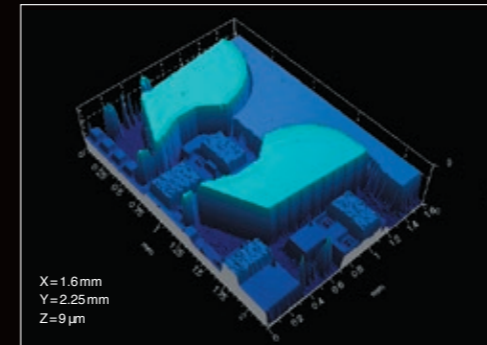

Flatness of a ceramic substrate (sintered part)

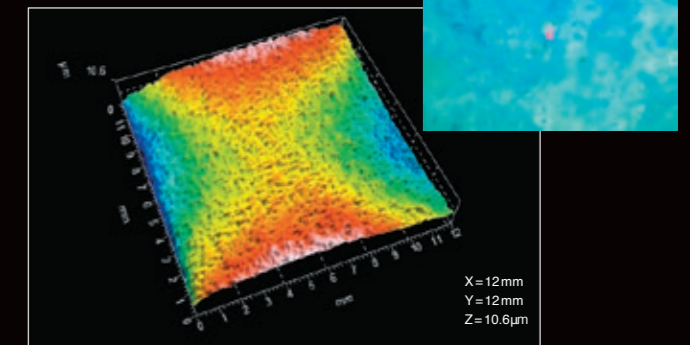

Wear volume of a brake pad (tribology)

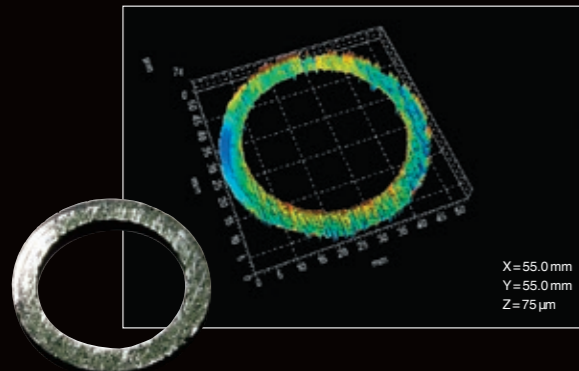

HDD head suspension (precision blanking)

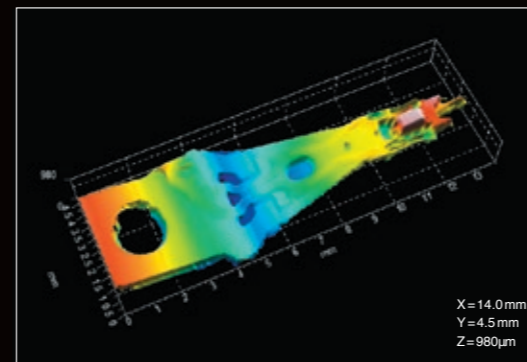

Flow marks (flow lines) of a molding

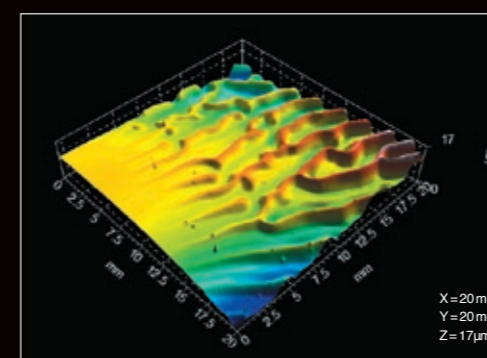

Braille (welfare)

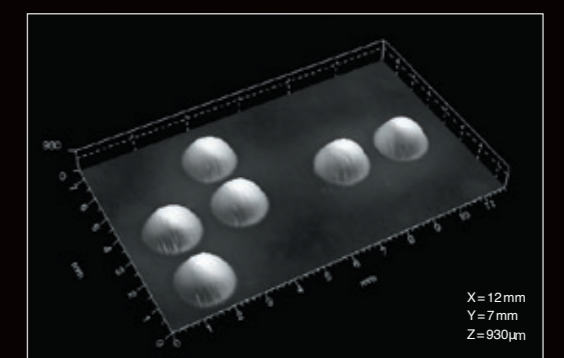

Tooth flank roughness of a precision gear (precision processing)

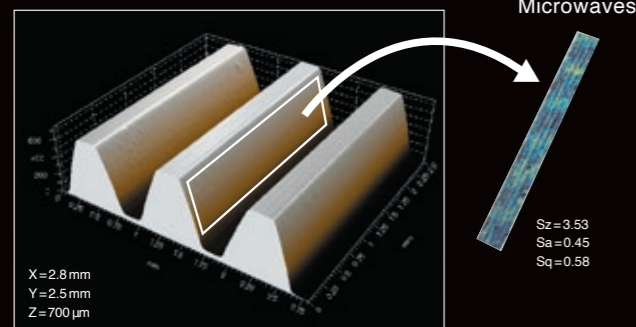

Grinding work surface (precision processing)

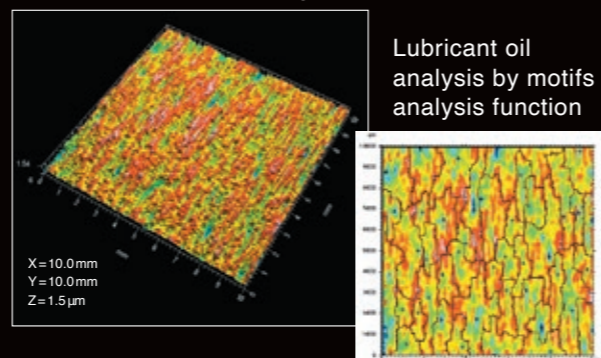

Fingerprint (medical & cosmetics)

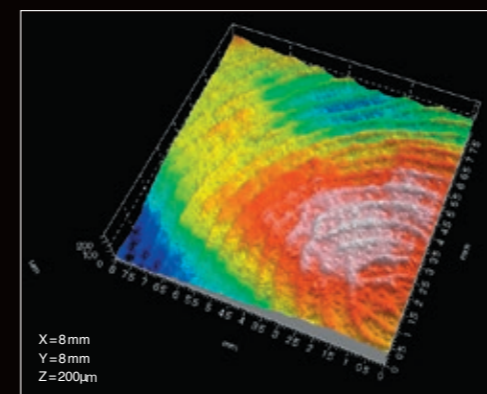

Human hair (cosmetics)

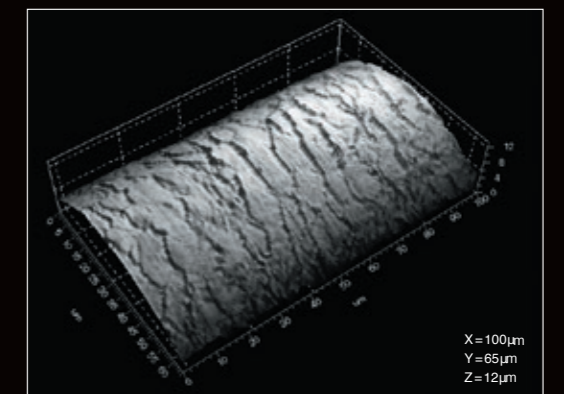

# 3D Surface Texture Analysis Software

## MitakaMap ST

Interactive and user-friendly software complete with powerful online help. Advanced analysis is carried out by applying straightforward operations to measurement data.

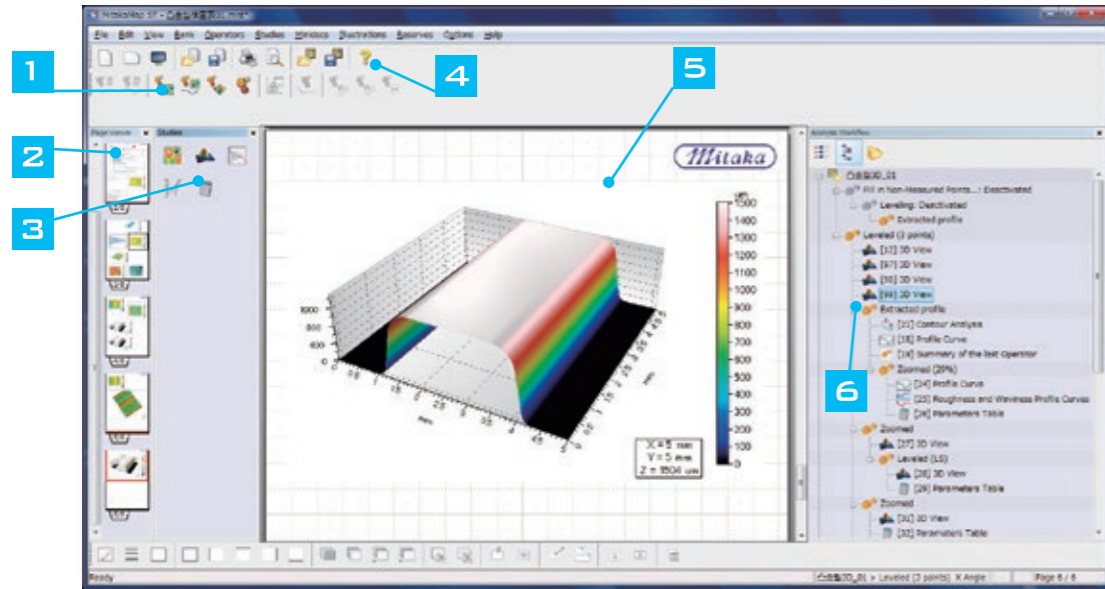

- 1 **Minidocs**  
Automatic analysis by insertion of pre-defined sequences of analysis steps
- 2 **Page viewer**  
Fast navigation to every page in the analysis report
- 3 **Studies**  
Icons for analytical studies applicable to the selected data set
- 4 **Online help**  
Detailed descriptions of all studies and operators
- 5 **Document page**  
Current page in the analysis report
- 6 **Analysis workflow**  
Tree view of all analysis steps in the report

# MitakaMap ST Automatic Analysis Tools

Surface metrology reports include comprehensive analysis results

## Inspection report creation

Reports containing analytical studies are created frame by frame in an intuitive desktop publishing environment. Headers, company logos, etc. on a master page are repeated on all pages of a report.

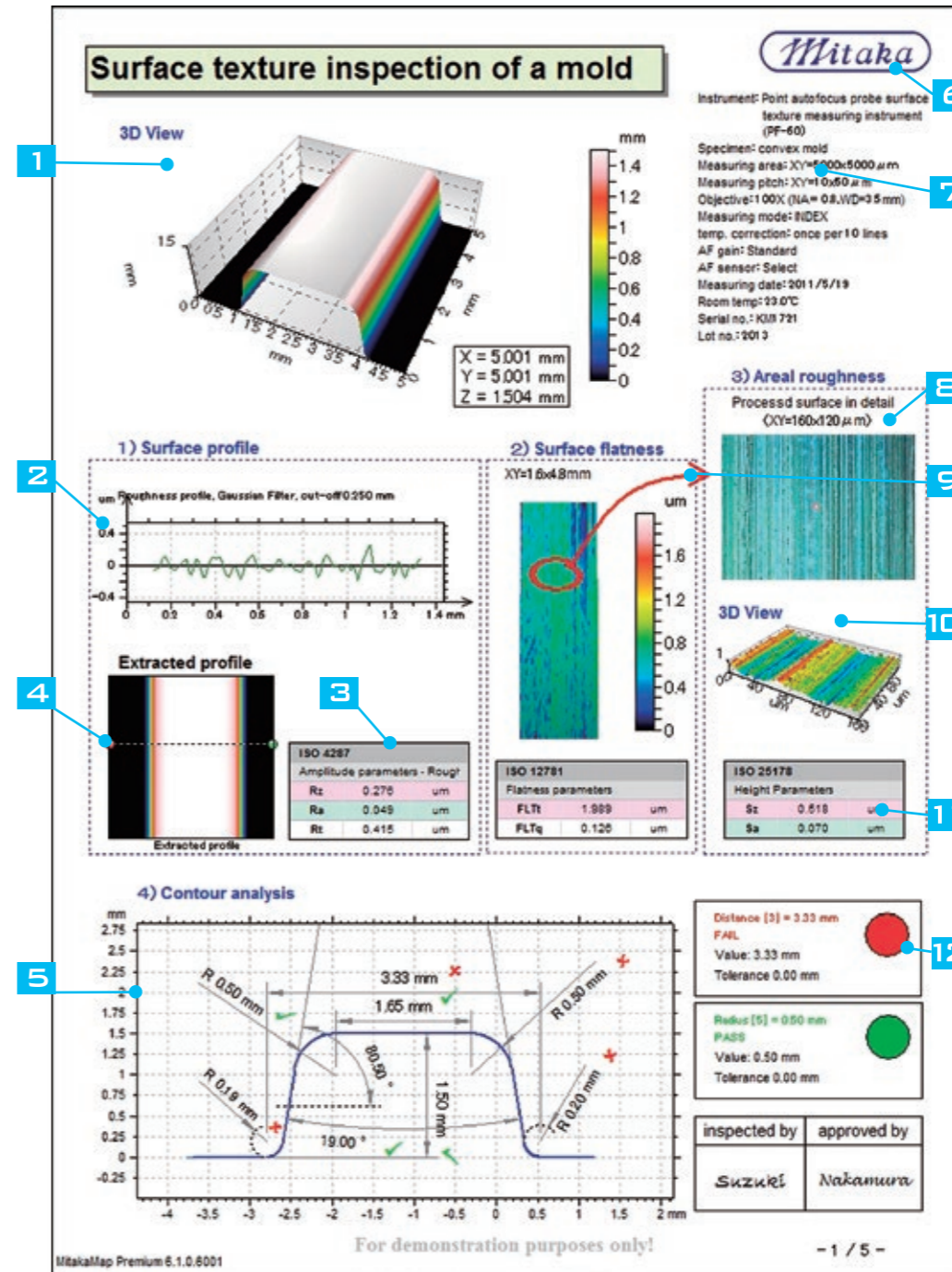

- 1 Measured result (1)  
The best visualization of data after leveling, removing noise, etc.
- 2 Part of the roughness profile after filtering of a primary profile extracted from the surface
- 3 Calculation of required parameters (selected from a family of parameters)
- 4 Selection of the profile for analysis (by dragging the black dotted line)
- 5 Contour analysis of the extracted primary profile. Automatic PASS/FAIL function is available with pre-defined tolerance limits.
- 6 Insertion of company logo
- 7 Identity card with information about the measurement
- 8 Microscope image of the workpiece pasted into the document
- 9 Framed borders for emphasis
- 10 Measured result (2)  
3D View of surface texture
- 11 Colored cells for emphasis
- 12 PASS/FAIL test results

### 2D surface texture analysis

Primary profile (P-parameter) Roughness (R-parameter) Waviness (W-parameter)

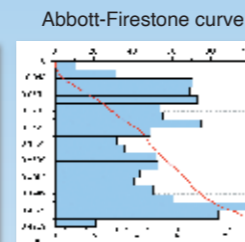
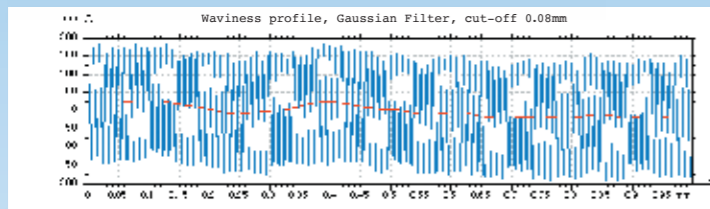

**Standard parameter**  
(ISO 4278/JIS B 0601, ASME B46.1)

- Height (peak and valley)  
 $R_z, R_a, R_p, R_v, R_c, R_q, R_{sk}, R_{sq}$
- Spacing:  $R_{sm}, R_{dq}$
- Material ratio:  $R_{mr}, R_{dc}$
- Peak:  $P_{pc}$

Result: Roughness:  $R_a=0.102, R_z=0.331, R_{sm}=10.0 (\mu m)$  Waviness:  $W_z=0.041 (\mu m)$

Extensive filter types: Gaussian filter, Double Gaussian filter, Spline filter, Robust Gaussian filter, 2RC-ISO, 2RC-PC

### Profile analysis

**Contour analysis** Automatic calculation of width, height, curvature and distance. The tolerance limit function is a perfect solution for quality control of precision parts.

Vee-groove analysis

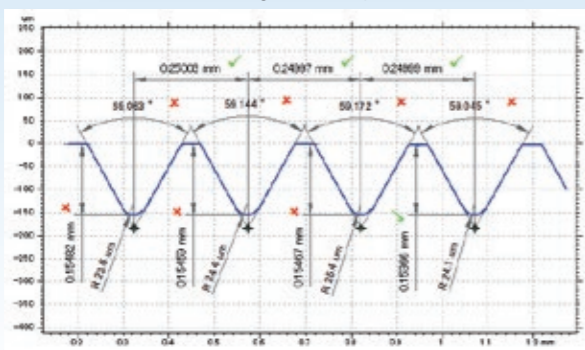

### Areal surface texture analysis

Parameters defined in ISO 25178 are pre-installed.

**Standard parameters**

- Height:  $S_z, S_a, S_p, S_v, S_q, S_{sk}, S_{ku}$ , ISO 4278-2, ASME B46.1, EUR15178N
- Flatness:  $FLT_t, FLT_p, FLT_v, FLT_q$  (ISO 12781)

Surface after electrical discharge machining (laser spot radius  $R=0.5 \mu m$ )

**ISO 25178**  
Height Parameters

- $S_z$  3.2665  $\mu m$
- $S_a$  0.2167  $\mu m$
- $S_q$  0.2779  $\mu m$
- $S_{sk}$  0.6995
- $S_{ku}$  5.6783

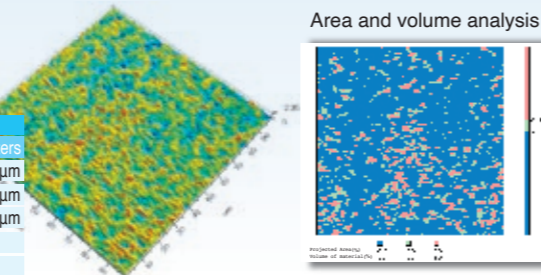

### Batch processing of data

Prepare an inspection report on a single data set and use it as a template for analyzing all similar data sets.

Creating automatic inspection reports



### Supporting 10 languages

MitakaMap supports 10 languages, facilitating global cooperation.

[Supported languages]

- Japanese
- English
- French
- German
- Italian
- Chinese
- Korean
- Spanish
- Polish
- Brazilian Portuguese

# MitakaMap XT Expert

MitakaMap XT is available as an upgrade to MitakaMap ST (standard software) and contains parameters required for R&D and specialized applications. It also provides extended quantitative analysis of surface texture.

# Advanced Contour Module

Additional operators and studies for Contour Analysis (standard) and Advanced Contour Analysis (optional module) provide powerful dimensional and form deviation analysis

### Worn metal surface\*

ISO 25178	
Height Parameters	
Sz	5.19 μm
Sa	0.56 μm
Sq	0.81 μm
Ssk	-2.02
Sku	7.31

### Additional functions

#### 2D advanced surface texture analysis

- ISO, JIS and other 2D parameters (ten point height of the roughness profile (RzJIS), etc.)
- Frequency spectrum (FFT) analysis
- Fractal analysis
- Morphological filtering

#### 2D automotive analysis

- R&W motifs analysis (ISO 12085)
- Graphical study of Rk parameters (ISO 13565)
- Rk profile

#### 3D advanced surface texture analysis

- Additional 3D parameters defined in ISO 25178 (spatial, hybrid, and functional volume)
- Graphical study of Sk parameters
- Graphical study of volume parameters
- Peak distribution
- Frequency spectrum (FFT) analysis
- Averaged power spectrum density
- Fractal analysis
- Measurement of a wrinkle
- Vectorization of the micro-valleys network
- Texture direction, isotropy

#### Primary profile at right angle to the groove\*

Flat surface with deep flaws

#### Motifs analysis JIS B0631 (ISO 12085)

Analyzing curves between peaks

#### Robust Gaussian filter\*

Impervious to scratches and steep asperity

#### Morphological filter JIS B0610

Waviness extracted by morphological dilation

#### Measurement of a wrinkle

Individual analysis of surface scratches and wrinkles

#### Section (standard specification)

Dividing the measured area by height & calculating area and volume

#### Vectorization of the micro-valleys network

Calculating the depth and position of every furrow to analyze the depth distribution and the mean density of the furrows

#### Graphical study of volume parameter

Visualizing proportions of peaks, valleys and cores / kernels

#### Frequency spectrum

FFT analysis of a surface

#### Texture direction

Direction of scratches and furrows

#### Averaged power spectrum density

Studying the relationship between wavelength (X) and roughness (Y)

### Example of form deviation analysis

#### Batch processing of data

Tabulating the analysis results and automatically displaying deviations from pre-defined tolerances

Parameter	Value	Lower limit	Upper limit	Pass or Fail
Radius [2]	1500.00 μm	1400 μm	1500 μm	Pass
Radius [3]	190.28 μm	195 μm	205 μm	Pass
Radius [4]	200.5 μm	195 μm	205 μm	Pass
Radius [5]	190.88 μm	195 μm	205 μm	Pass
Radius [6]	194.17 μm	195 μm	205 μm	Fail
Radius [7]	204.52 μm	195 μm	205 μm	Pass
Radius [8]	196.47 μm	195 μm	205 μm	Pass
Radius [9]	197.07 μm	195 μm	205 μm	Pass
Distance [1]	1500.04 μm	1480 μm	1500 μm	Pass
Distance [4]	1000.48 μm	990 μm	1000 μm	Pass

#### CAD data comparison

Loading CAD data in order to compare measured profiles with design specifications

#### Dimensional analysis of osculating circle

Analyzing contact points and center coordinates with respect to virtual circles

- 1 Analysis tools**  
Tools for width, distance, height, radius, diameter, angle of intersection, horizontal angle, angle of an arc, etc.
- 2 Creating segments**  
Associating segments (lines and arcs) with a measured profile for dimensional analysis
- 3 DXF input**  
Loading CAD data (DXF) in order to compare the measured profile with design specifications
- 4 Residue tool**  
Graphical study of form deviations of straight lines and arcs (Pz, Pa, Pq, etc.)
- 5 Deviation tool**  
Viewing magnified form deviation graphics and highlighting out of tolerance data points in red
- 6 Coordinate conversion tools**  
Changing leveling position and the origin
- 7 Analysis window**  
Analysis space for scaling a profile, positioning dimension lines and numeric results

# Motifs Analysis

Dividing surface asperity into ridge and course lines in order to extract local peaks and pits for detailed surface observations

#### Visualization of motifs

Dividing peaks by course lines

#### Batch output of analysis result

Numbering all motifs and exporting the full set of numerical results to a text file

#### Individual analysis

Visualizing an individual motif and generating its specific parameters

#### Batch output of analysis result

Numbering all motifs and exporting the full set of numerical results to a text file

**[Motif Parameters (Typical parameters)]**

Number of motifs	Type of Motif	Height	Area	Volume	Extremum of XYZ
Nb of neighbors	Pitch (max/min/mean)	Coflatness	Perimeter	Mean diameter (max/min/mean)	
Form factor	Aspect ratio	Roundness	Compactness	Orientation	Sphere radius

Height: 2.02μm  
Area: 0.004mm<sup>2</sup>  
Volume: 867.8μm<sup>3</sup>

\*also available in ST



Mitaka Kohki provides a range of point autofocus probe measuring instruments including NH-Series, non-contact 3D measuring instruments, and MLP-2, a 360 degree form measuring instrument. The NH-Series is a perfect solution for measuring dimensions and surface texture and the MLP-2 is ideal for rotative measurement. Mitaka point autofocus systems are widely installed in ultraprecision machining manufacturers, electronic components, optical components and other industrial fields.

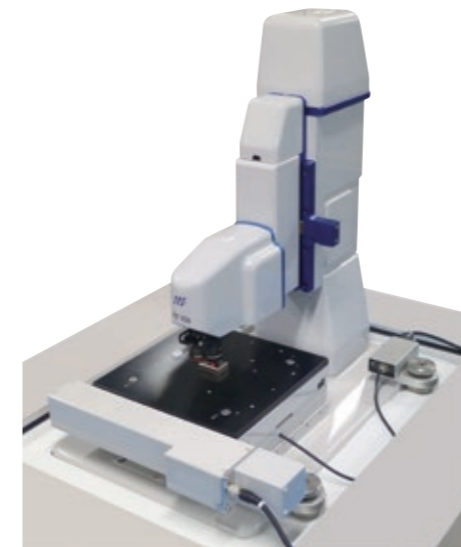

Model: PF-150 (6-inch scanning model)  
 Measuring range: XYZ = 150mm X 150mm X 10mm  
 Scale resolution: XYZ = 0.1μm, 0.1μm, 0.01μm  
 Applications: grinding wheels, optical components, molds and dies, etc.

Model: PF-600 (large scanning model)  
 Measuring range: XYZ = 600mm X 600mm X 10mm  
 Scale resolution: XYZ = 0.1μm, 0.1μm, 0.01μm  
 Applications: large optical components, large molds and dies, LCD panels, etc.



Model: NH-3SP (Super precision model)  
 Measuring range: XYZ = 150mm X 150mm X 10mm  
 Scale resolution: XYZ = 0.01μm, 0.01μm, 0.001μm  
 Applications: aspherical lenses, semiconductors, precision molds, etc.



Model: MLP-2 (360-degree measurement model)  
 Measuring range: XYZ = 120mm X 90mm X 130mm  
 AF (R) = 40mm, AZ (θ) = 360°  
 Scale resolution: XYZ = 0.1μm, 0.1μm, 0.1μm  
 AF (R) = 0.01μm, AZ (θ) = 0.001°  
 Applications: precision gears, endmills, punches, molds for connectors, etc.

Mechanical Section				Software
Axes	X axis	Y axis	AF (Z1) axis (for measurement)	Z2 axis (for positioning)
Measuring range	60mm	60mm	10mm	60mm
Positioning resolution	0.1 μm	0.1 μm	0.01 μm	0.1 μm
Scale	Glass Scale	Glass Scale	Glass Scale	Pulse
Accuracy (L=length in mm)	(2+4L/1000)μm	(2+4L/1000) μm	(0.3+0.5L/10) μm	—
Autofocus optical system	Repeatability	σ =0.03 μm (at mirror (specimen) surface)		
	Focus area	φ 1 μm (with 100X objective)		
	Laser	Semiconductor laser (o/p: 1mW Max λ: 635nm class 2)		
	Objective for measurement	100X (WD=3.4m NA=0.8) observation mag : approx.1100X (9-in monitor)		
	Objective for positioning	5X (slide mechanism) [field of view]		
Epi-illumination	Köhler illumination (light source: white LED)			
Other	Dimensions of XY stage	210x210mm		
	Max sample size	70mm (up to 100mm in height with AF unit)		
	Max sample weight	4kg		
	Instrument size (WxDxH)	Mechanical section: 400 × 400 × 450mm		
	Vibration isolator	3 point supporting pad (proper oscillation lateral: 3.5 vertical: 4Hz)		
Instrument weight	31kg			
Controller				
User interface	Personal computer (OS: Windows)			
Drive control	4-axial controller (MSCN-4N)			
Power consumption (total)	250W (100V2.5A)			
<ul style="list-style-type: none"> <li>○ 2D/3D surface texture measuring software                             <ul style="list-style-type: none"> <li>■ Profile</li> <li>■ Areal (index/ scanning mode)</li> </ul> </li> <li>○ 3D surface texture analysis software (MitakaMap ST)                             <ul style="list-style-type: none"> <li>■ Profile surface analysis texture analysis (ISO 4287) roughness / waviness / primary profile height, width, peak, material ratio parameters</li> <li>■ Areal surface texture analysis (ISO 25178) Areal height parameters</li> <li>■ 3D view</li> <li>■ Form removal</li> <li>■ Morphological filters</li> <li>■ Distance, Step-height analysis</li> <li>■ Volume of holes and peaks</li> <li>■ Minidocs</li> <li>■ 10 languages supported</li> <li>■ Animation view</li> <li>■ Contour analysis</li> <li>■ Abbott Curve</li> <li>■ Illustrations</li> </ul> </li> <li>○ Image Capture (Mitaka Veiver)                             <ul style="list-style-type: none"> <li>■ reticle/scale display</li> <li>■ saving images</li> </ul> </li> <li>○ Data export                             <ul style="list-style-type: none"> <li>■ Excel-compatible ASCII text files</li> </ul> </li> </ul>				
Optional software				
<ul style="list-style-type: none"> <li>○ Advanced Contour Module</li> <li>○ Motifs Analysis</li> <li>○ Statistics</li> <li>○ Upgrade to MitakaMap XT</li> </ul>				
Other options				
<ul style="list-style-type: none"> <li>○ 50X objective (WD=10.6mm NA=0.5)</li> <li>○ High NA100 X objective (WD=0.35mm NA=0.95)</li> </ul>				

# Mitaka

**MITAKA KOHKI CO., LTD.**

1-18-8 Nozaki, Mitakashi, Tokyo 181-0014 Japan  
TEL +81(0)422-49-1491 FAX +81(0)422-49-1117  
<http://www.mitakakohki.co.jp>  
E-mail: [sales@mitakakohki.co.jp](mailto:sales@mitakakohki.co.jp)



For information only.  
Specifications subject to change  
without prior notice.

Distributor

**TRADING**

2M TRADING EOOD

[2emtrading.com](http://2emtrading.com)

[info@2emtrading.com](mailto:info@2emtrading.com)

Nadezhda District,

10 Petko D. Petkov str.,

entr. A, ap. 24, 1231

Sofia, Bulgaria

+359 88 740-2046

+359 88 252-1705

