

A close-up photograph of a Mitaka NH-3 SPs Point Autofocus Probe 3D Measuring Instrument. The device is primarily white with blue accents. It features a vertical probe arm at the top, a central body with a lens and a yellow laser warning symbol, and a rotating stage at the bottom. The text 'NH-3 SPs' is printed on the central body. The background is a light blue gradient.

NH Series

Point Autofocus Probe

3D Measuring Instrument

*M*  
NH-3 SPs

*Mitaka*

Point autofocus probe  
Non-contact 3D measuring instrument

# NH Series

Highest-end model with 1nm resolution  
[Applications]  
Shape measurement, inspection of aspherical lenses, light guide plates, molds, etc.

## NH-3SPs

Measuring range (X, Y, Z) = 150 × 150 × 10 mm  
Z = 130 mm (Optional)  
Resolution (X, Y, Z) = 0.01 × 0.01 × 0.001 μm



### Awards

**The METI Minister's Prize**  
The Fifth Monozukuri Nippon Grand Award

**The 10<sup>th</sup> Excellent New Technologies and Products Award for small and medium-sized enterprises**  
The Resona Foundation and Nikkan Kogyo Shimibun, Ltd.

**Excellent Product Award**  
JSME

**The Technical Achievement in Production Processing / Working Machines**  
JSME

Largest model with gate-type structure  
[Applications]  
Large and heavy precision molds

## NH-5Ns

Measuring range (X, Y, Z) = 300 × 400 × 10 mm  
Z = 130 mm (Optional)  
Resolution (X, Y, Z) = 0.1 × 0.1 × 0.01 μm



Standard model which offers excellent functions and high-cost-performance

## NH-3Ns

Measuring range (X, Y, Z) = 150 × 150 × 10 mm  
Z = 110 mm (Optional)  
Resolution (X, Y, Z) = 0.1 × 0.1 × 0.01 μm

Perfect solution for quality control of semiconductor products  
[Applications]  
8-inch wafer, lead frame, etc.

## NH-4Ns

Measuring range (X, Y, Z) = 250 × 200 × 10 mm  
Z = 110 mm (Optional)  
Resolution (X, Y, Z) = 0.1 × 0.1 × 0.01 μm



Excellent model for measuring forms and evaluating optical characteristics

## NH-3MA s

Measuring range (X, Y, Z) = 100 × 100 × 10 mm  
Resolution (X, Y, Z) = 0.1 × 0.1 × 0.01 μm

# ISO-approved measurement method

## ISO 25178-605

Areal surface texture - non-contact 3D measuring instrument (point autofocus probe)

**Measurement principle conformed to the ISO standard (ISO 25178-605) offers highly reliable data.**

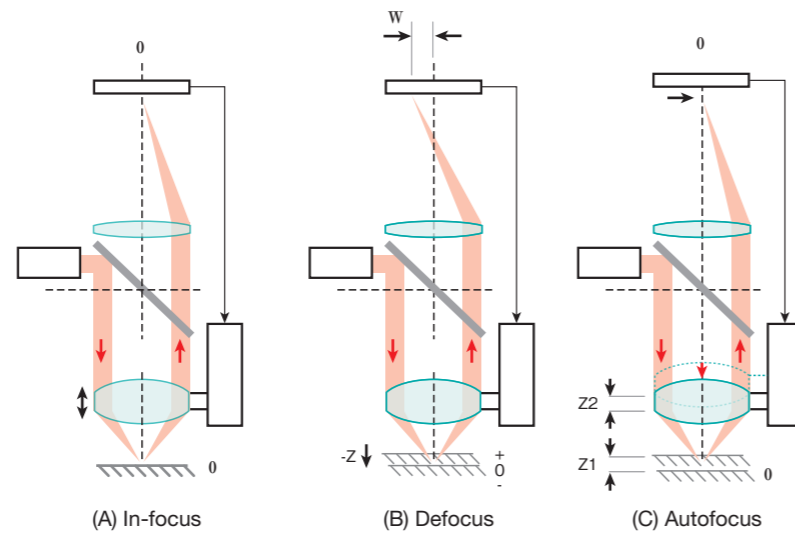

Principle of point autofocus instrument

The NH Series consists of an autofocus laser beam microscope (AF microscope) and a high precision XY scanning stage. In the figure above, the laser beam incorporated in the AF microscope passes through the objective (indicated by the red line) and forms a laser spot on the surface of the workpiece as a "probe". The reflected laser beam from the workpiece surface passes through the objective again and forms an image on the autofocus sensor (AF sensor). The AF sensor detects the laser spot displacement in real time and adjusts the AF microscope back to the in-focus position. This measuring method, point autofocus profiling, is immune to the surface colors and reflectivity as the AF sensor detects the position of the laser spot. In addition to the conventional index measurement mode, the scan autofocus measurement mode provides high speed measurement and high precision measurement.

## ISO standards for areal surface texture measurement

The autofocus method adopted into the NH series is based on a measurement principle that was proposed to ISO by a project team led by Mitaka Kohki in the domestic ISO committee. The method was named as "Point autofocus profiling" in 2008 and was officially standardized as ISO 25178-605 (Point autofocus probe) in February 2014.

### Classification of areal surface texture measurement methods in ISO Standards

ISO 25178-6 : Classification of methods for measuring surface texture

- 601 : Nominal characteristics of contact (stylus) instruments
- 602 : Nominal characteristics of non-contact (confocal chromatic probe) instruments
- 603 : Nominal characteristics of non-contact (phase-shifting interferometric microscopy) instruments
- 604 : Nominal characteristics of non-contact (coherence scanning interferometry) instruments
- 605 : **Nominal characteristics of non-contact (point autofocus probe) instruments**
- 606 : Nominal characteristics of non-contact (focus variation) instruments
- 607 : Nominal characteristics of non-contact (confocal microscopy) instruments

## High correlation with international standards for roughness measurement

Point autofocus profiling (PAP) has a high correlation with roughness standards for stylus instruments and obtains highly reliable data.

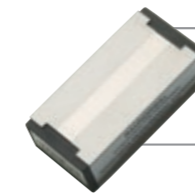

- Roughness standard: TypeD1 (ISO5436-1)
- Calibration: PTB (Germany)
- Cutoff value ( $\lambda c$ ): 0.8 mm
- Measurement method: stylus
- Tip radius: 5  $\mu\text{m}$
- Evaluation length (ln): 4 mm

(Stylus: tip radius R = 5  $\mu\text{m}$ )

PTB inspection sheet

Roughness parameters	PTB
(Ra)	0.227 $\mu\text{m}$ ( $\pm 3\%$ )
(Rz)	1.50 $\mu\text{m}$ ( $\pm 4\%$ )

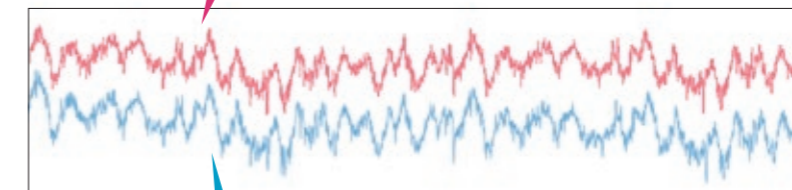

NH Series measurement result

Roughness parameters	NH-3SPs
(Ra)	0.229 $\mu\text{m}$
(Rz)	1.497 $\mu\text{m}$

(PAP: laser spot radius R = 0.5  $\mu\text{m}$ )

## Measurement precision with different standards

### Step height standards

#### ■ Step master (Mitutoyo)

Specification:  $(10 \pm 1.5) \mu\text{m}$  Measurement result: 10.012  $\mu\text{m}$   
\*Measuring instrument: NH-3SP

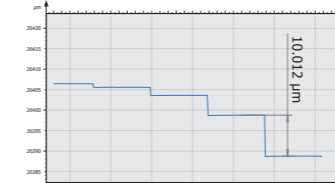

#### ■ Step height standards (VLSI Standards)

Specification:  $(1.779 \pm 0.011) \mu\text{m}$  Measurement result: 1.788  $\mu\text{m}$   
\*Measuring instrument: NH-3SP

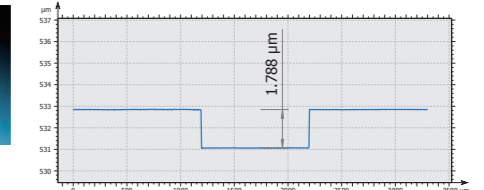

## Unique optical system and measurement methods

### Autofocus optical system cuts ghost and stray light

The autofocus optical system cuts out unnecessary light to achieve targeted measurement.

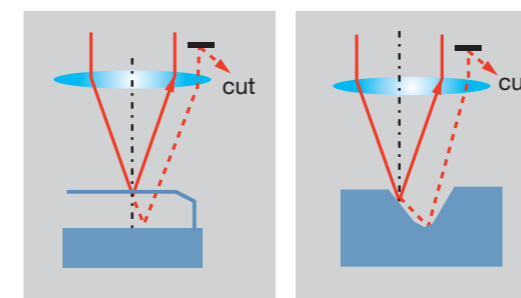

Transmissive surface

Secondary reflection of a Vee-groove

### Edge detection function that measures xy coordinates of step heights

Many non-contact size measuring instruments use CCD cameras to detect edges by setting an image gradient as a threshold\*. On the other hand, NH Series measures forms and detects edges of a workpiece by setting the  $\Delta Z$  from the surface height as a threshold. Hence, NH Series is immune to color and reflectance ratio of a surface and capable of measuring a large area in high precision. This function is essential for measuring dimensions of high precision, high density and enlarging semiconductor products and optical devices.

\*Image processing software (Optional) offers this function

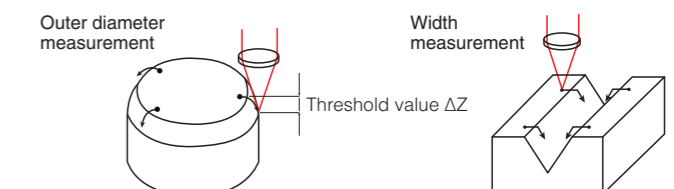

Outer diameter measurement  
Detects more than 3 edges and measures each radius and the central coordinate

Width measurement  
Detects more than 4 edges and measures each width and crossing angle

# Perfect solution for measuring all kinds of surface topography in high precision

## [Key features]

### No damage with non-contact measurement

The laser probe (non-contact probe) offers “no stylus wear” which leads to non-destructive measurement of a workpiece surface. Repetitive form and areal surface texture measurements of a costly precision mold can be easily done.

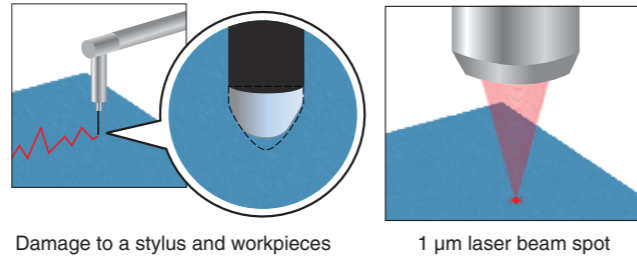

Damage to a stylus and workpieces

1  $\mu\text{m}$  laser beam spot

### Large measuring area and high precision measurement

The laser probe with a radius of 0.5  $\mu\text{m}$  and the precision XY scanning stage directly measure an area of several tens of millimeters down to the sub-micrometer level (measuring range: XYZ = 150 x 150 x 10 mm, scale resolution: XY = 0.01  $\mu\text{m}$ , Z = 0.001  $\mu\text{m}$  (model: NH-3SPs))

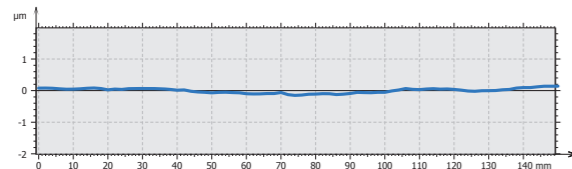

Straightness of the XY scanning stage  $\pm 0.107 \mu\text{m}$   
(Measuring length: 150 mm)

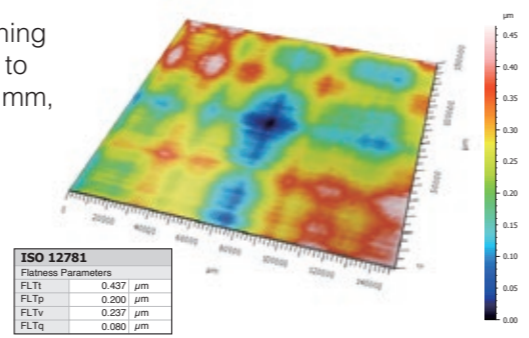

Flatness of the XY scanning stage: 0.437  $\mu\text{m}$   
(Measuring area: 150 x 150 mm)

### Excellent angle tracking capability

The highly sensitive autofocus sensor captures low levels of light reflected from the workpiece surface, allowing for the direct precision measurement of steep angles and step heights.

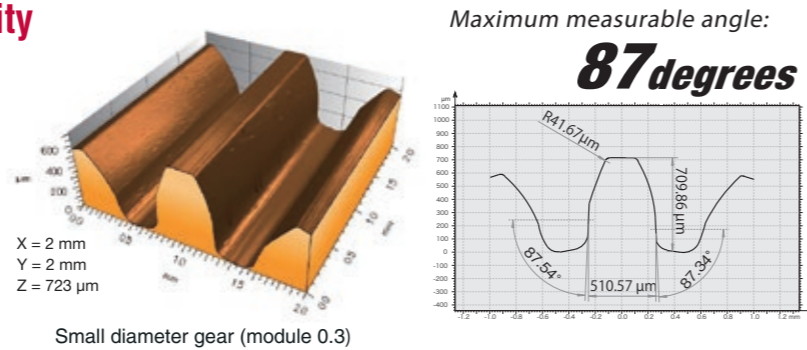

Small diameter gear (module 0.3)

### No influence of surface colors / reflectance

NH Series directly measures various types and materials of surfaces, such as coated glass with very low reflectance (approximately 0.5 %), mirror surfaces with reflectance of 90 % or greater, plastics, rubber, paper, thin films, etc.



### Live camera image of the measurement point

The built-in CCD camera offers a live view of the laser beam spot. Image processing function\* offers edge detection and circle measurement.

\* Optional

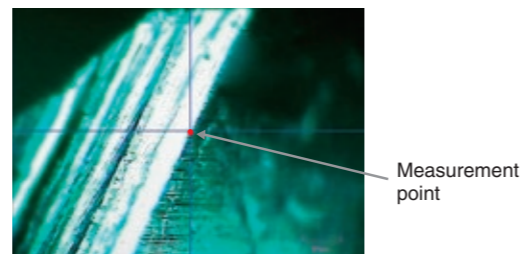

Measurement point

## [Measurement functions]

### Spatial coordinates Auxiliary functions

NH Series has various spatial coordinate construction functions to assist workpiece-oriented measurement. These auxiliary functions offer pinpoint measurements for efficient quality control.

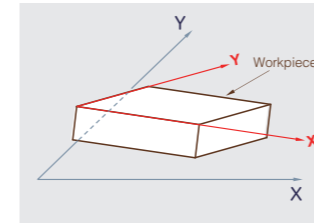

Alignment

Converts the absolute coordinate system of the instrument into the relative coordinate system of the workpiece.

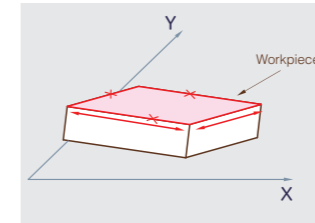

Reference plane creation

Creates a reference plane by measuring more than 3 heights (max. 300 points). Flatness can be calculated by measuring more than 10 heights.

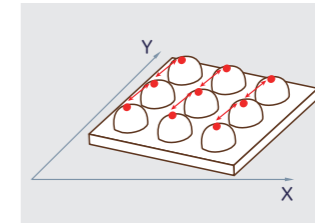

Point measurement

Measures heights of any line in an equal pitch. [Application] Waviness and warpage measurements of a lead frame.

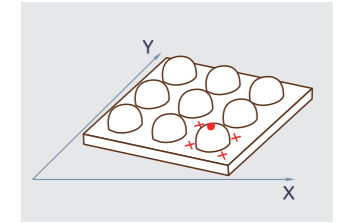

Height measurement

Obtains multi-points around the specified height position for a height measurement and calculates the average, max. and min. values. [Application] Max. height measurement of BGA.

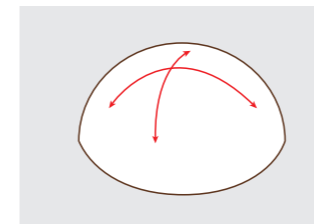

Curve

Measures the curvature either by measuring heights on two specified circles or cross measurement.

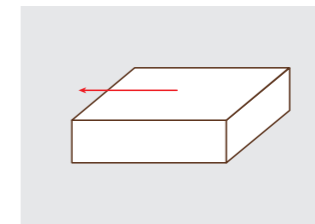

Edge

Detects an edge by setting a threshold value.

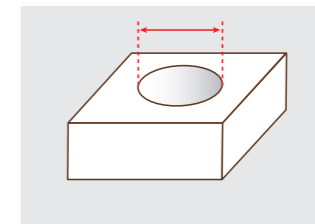

Circle

Detects the center point and the radius of a circle, a circular cylinder or a hole.

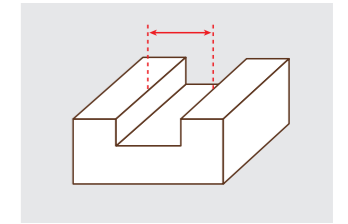

Width

Measures a width of a groove or a rectangular parallelepiped by defining two lines for specifying the width.

### Application example

#### Macro measurement

Macro measurement offers automatic measurement and evaluation by linking image processing function\*, spatial coordinate function and specified point measurement function of the point autofocus probe. \*Optional

- 1 Align the workpiece at the specified position
- 2 Measure the specified area for warpage evaluation
- 3 Measure the specified length for step height evaluation and carry out PASS / FAIL tests
- 4 Measure the heights of the specified positions

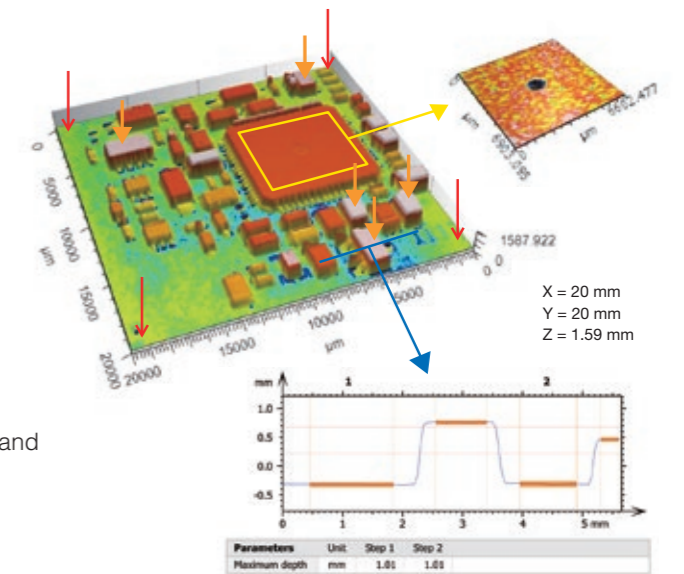

X = 20 mm  
Y = 20 mm  
Z = 1.59 mm

# NH Series solves various measurement problems

## [Comparison with other measurement methods]

**Problem with contact probe**

The stylus scratches the workpiece surface

- △ Cannot measure soft and sticky workpiece
- △ Cannot accurately set the measurement position
- △ Stylus wears out

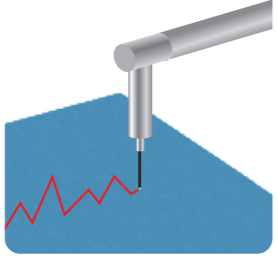

**NH Series solution**

Non-contact measurement preserves the workpiece surface

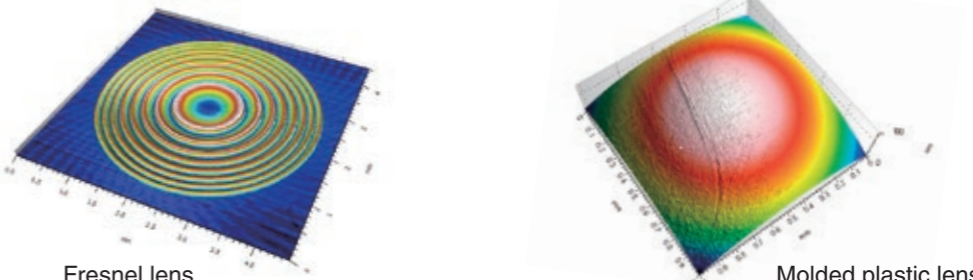

Fresnel lens      Molded plastic lens

**Problem with laser microscope**

The measurement range is its field of view

- △ Patching is necessary for large area measurement
- △ Cannot program automatic measurement

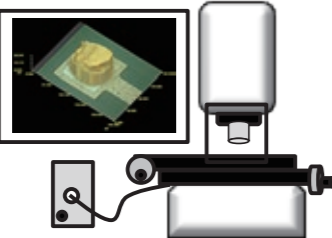

**NH Series solution**

Stage movable range is the measuring range which directly measures a large area

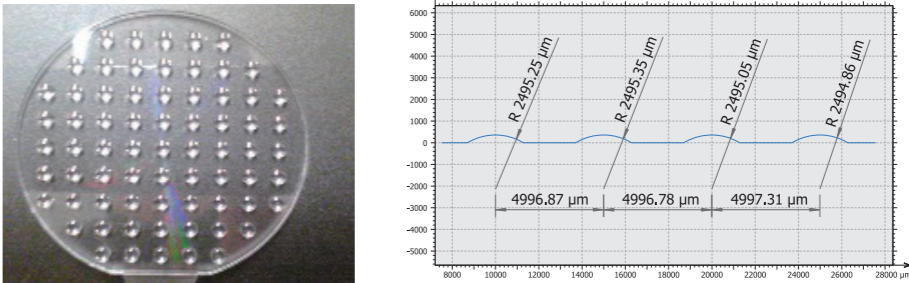

Array lens: pitch 5 mm      Pitch evaluation in the large area

**Problem with interferometry**

Unable to measure large form changes

- △ Cannot measure slopes
- △ Only measures within the field of view
- △ Cannot measure warpage in the order of several millimeters



**NH Series solution**

Easily measures steep slopes and rough surfaces

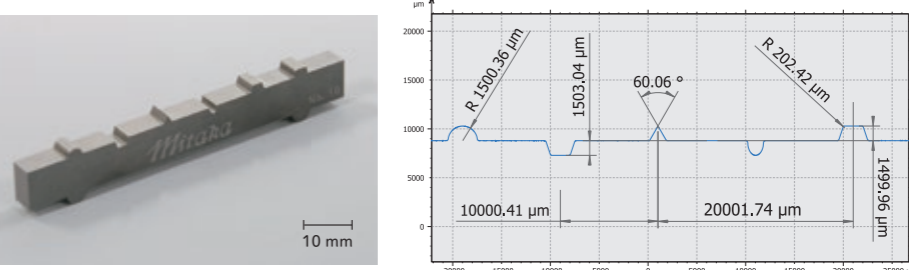

Contour reference material (EDM)

**Problem with focus variation**

Unable to measure mirror surface

- △ Cannot measure surface roughness of mirror-finished surfaces
- △ Surface treatments are necessary for transparent workpiece

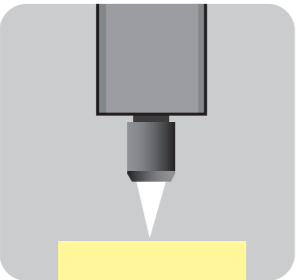

**NH Series solution**

Directly measures mirror surfaces and transparent materials without surface treatments

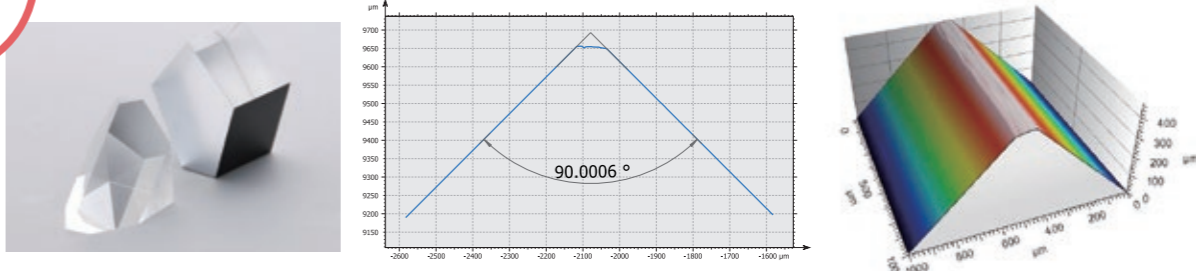

Apex angle of a prism

# Perfect solution for measuring all kinds of surface topography

## [Measurement examples]

### Fresnel lens

Precision measurement of transparent steep slopes

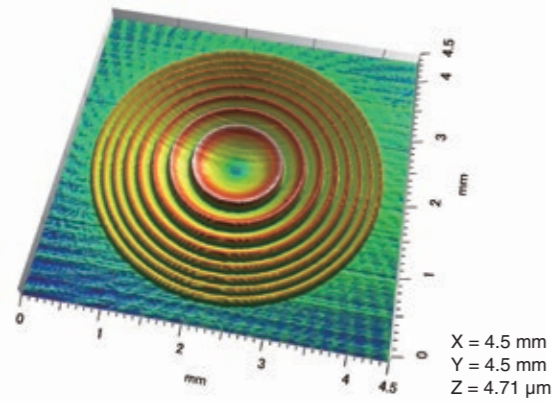

### Grating

High speed measurement of sub-micrometer grooves in high precision

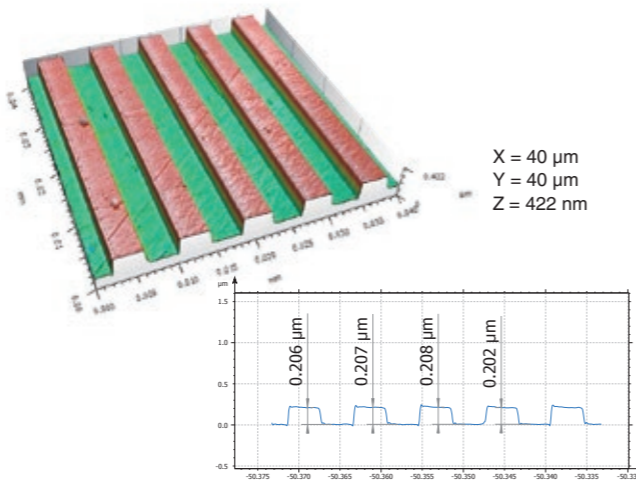

### Microlens arrays

Precisely tracks irregular lens surface

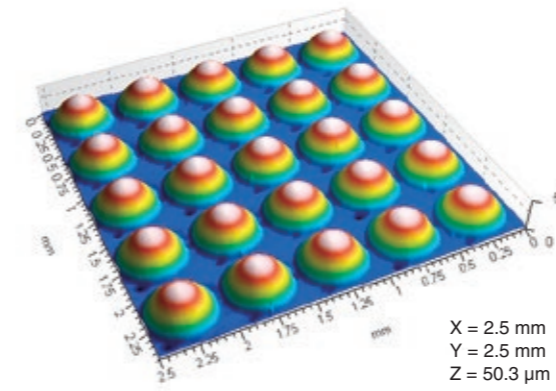

### Dicing blade warpage

Doughnut measurement (mask measurement) offers automatic high-speed measurement

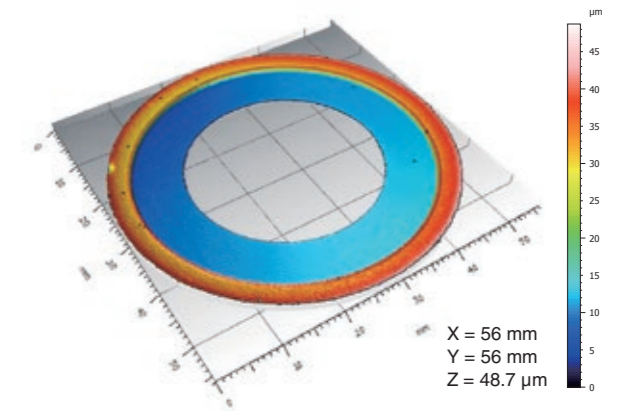

### Large aspherical lens

Direct measurement of a large area

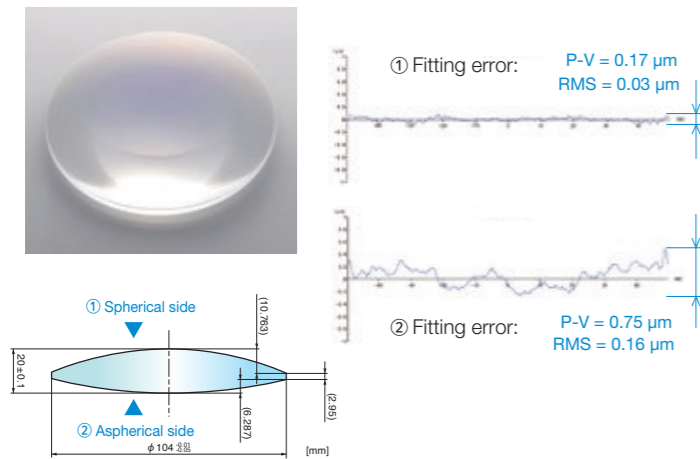

### HDD head suspension

Waviness and warpage of delicate parts

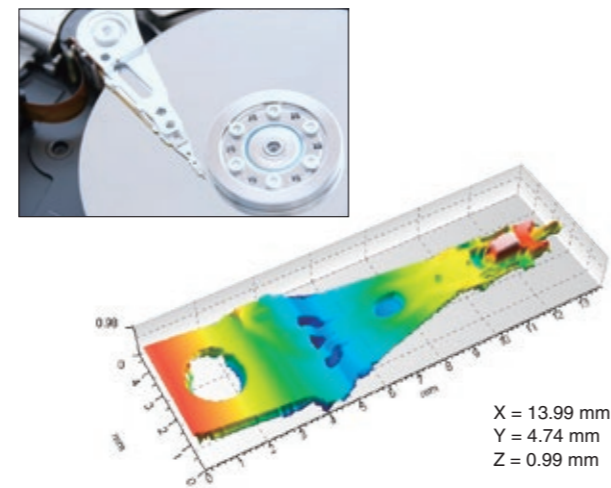

### Warpage and waviness of wafer

High speed measurement of the entire warpage and waviness

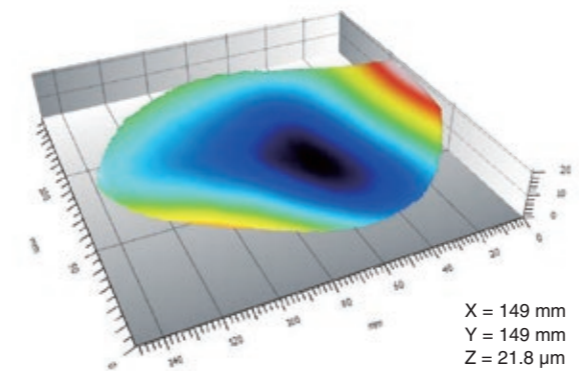

### BGA volume

Volume evaluation from areal surface measurement result

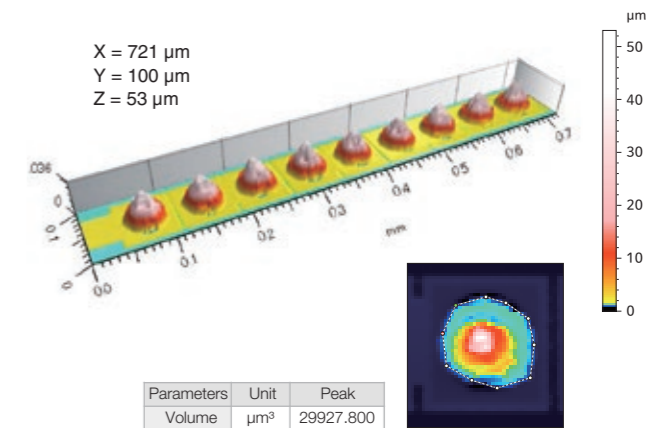

### Light guide panel

Vee-groove measurement of an optical component

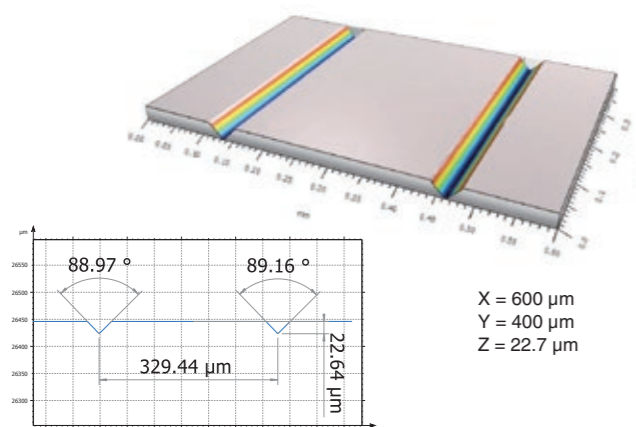

### HUD glass

Free form glass surface measurement and CAD comparison\*

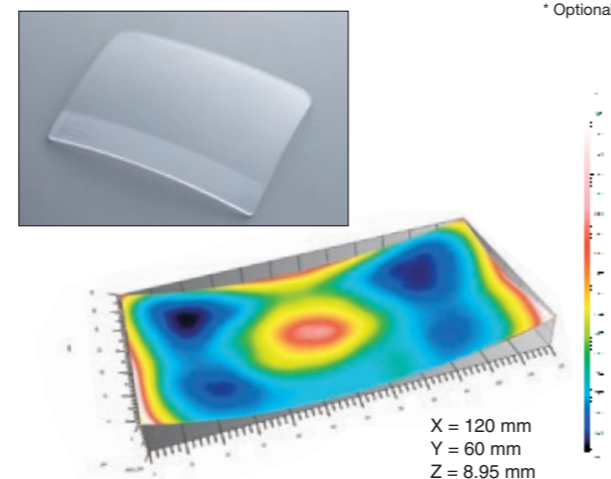

### Tip of turning tool

High precision measurement of the entire form and fine area

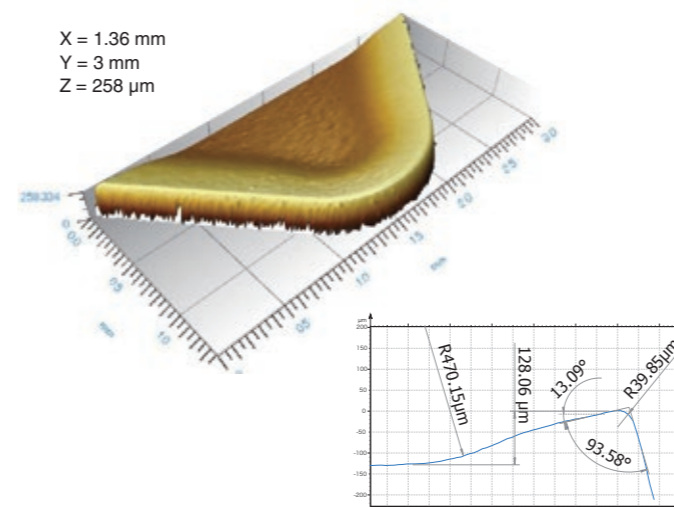

### Diamond round cuttin tool

High precision measurement and comparison with the design values

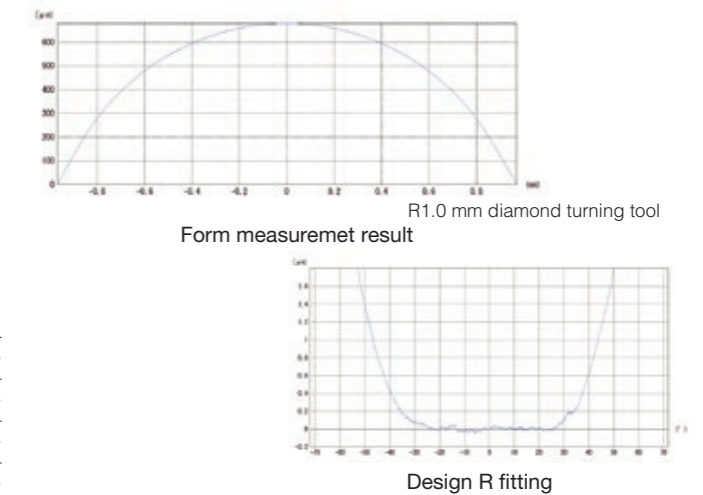

# Rotation stage mechanisms

## High NA aspheric surface measuring device (SE stage)

Stitching measurement technology enables sub-micrometer measurement of aspherical lens with the inclination angle greater than 60 degrees

NH series offers precision measurements with absolute accuracy of less than  $\pm 0.1 \mu\text{m}$  at the inclination angle within  $\pm 30^\circ$ . For any high NA aspherical lens with the inclination angle greater than  $\pm 30^\circ$ , stitching measurement technology described in the figure below offers high-precision measurements up to  $\pm 90^\circ$ .

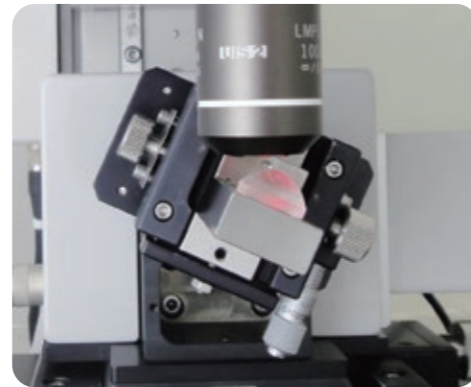

### How to measure an inclination angle greater than $\pm 30^\circ$

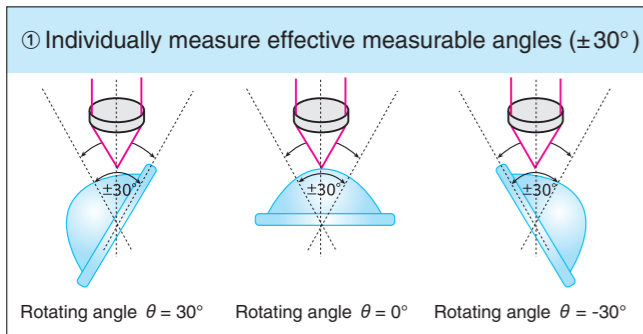

Evaluation result of a glass reference sphere

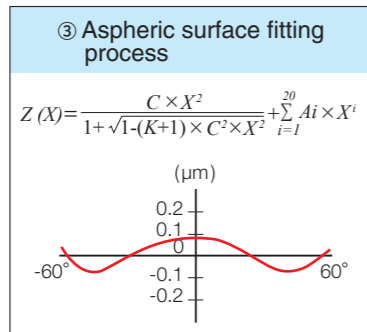
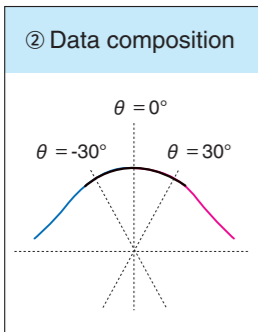
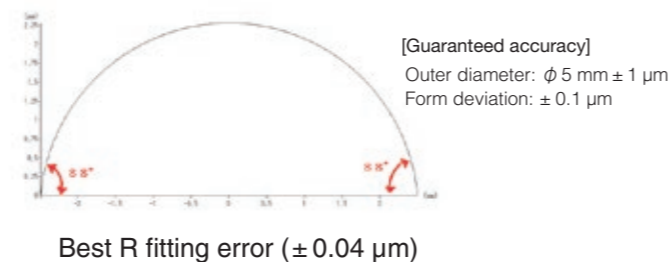

[Result]  
Diameter: 5.0001 mm  
Form deviation:  $\pm 0.0415 \mu\text{m}$

[Applications]

- Cell phone camera lens
- Digital camera lens
- DVD pickup lens
- Condenser lens
- Ball lens
- Microlens arrays
- Nose profile (tip) measurement of diamond cutting tool
- Optical fiber tip radius measurement
- Endoscope lens
- Aspherical lens molding dies

## Entire circumference measuring device (EL stage)

Non-destructive, 360-degree contour and roughness measurements

The precision elevation stage (EL stage) does not require centering of a workpiece for 360-degree entire circumference measurements. EL stage is a powerful tool for contour measurements of precision gears, punches for precision press dies, roundness measurements of ball lenses, surface roughness measurements of specific parts and quality control of precision parts.

### Measurement examples

- Precision gears
- Polished shafts
- Contour measurement of punches for precision press dies
- Roundness measurement of ball lenses



Micro punch

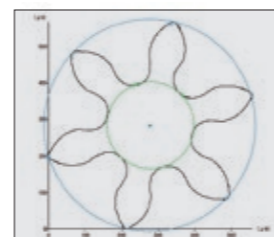

Precision gear

# Image processing software

## Mitaka Imager

### Clear image with good repeatability

The high speed and high precision laser autofocus quickly obtains clear images with good repeatability. Precision size measurements can be done simultaneously. (repeatability of line width measurement  $3\sigma = 0.01 \mu\text{m}$ )\*

### Precision measurement

By linking the linear scale values of the XY scanning stage with the image coordinate values via Mitaka Imager, NH Series offers precision measurement in the entire movable range.

### Applications of detected and evaluated data

Every image processing measurement data can be saved in CSV file format. Commercially available spreadsheet software (MS Excel) easily loads the measurement data for statistical processing, generating reports, etc.

### Enhanced automatic measurement

Mitaka Imager enhances teaching macro function of NH software:

- Apply the gravity center positions of circle patterns obtained through particle detection function and / or the pattern position obtained through pattern matching function for reference points in alignment function
  - Quickly move the XY scanning stage to these detected positions
- Mitaka Imager is equipped with various dynamic link functions.

### Particle detection

Particle detection measures positions, areas, widths, heights, circumferences and numbers of particles. The obtained data can be used for moving the XY scanning stage to the detected particles and for creating the alignment.

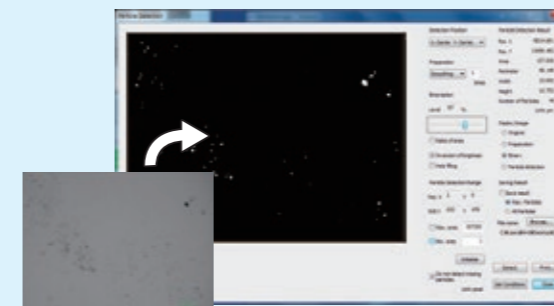

### Edge detection

Edge detection measures line widths, groove widths, central coordinate, inclination, etc.

[Applications] Widths and heights of optical waveguide, gap measurement of various magnetic heads, width and depth measurements of vee-grooves, pattern widths of LCD and PDP, etc.

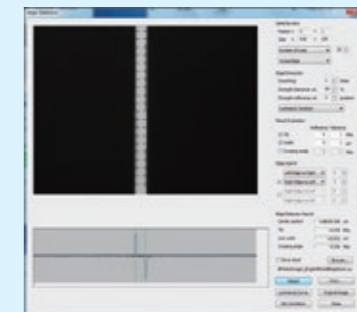

### Circle measurement

Circle measurement offers inside and outside diameter at any Z positions in high precision and calculates position of center, radius, roundness and area. Also, by linking with the XY linear scale values, a workpiece with a large diameter (out of field-of-view measurement) can be measured in high precision without lowering the magnification.

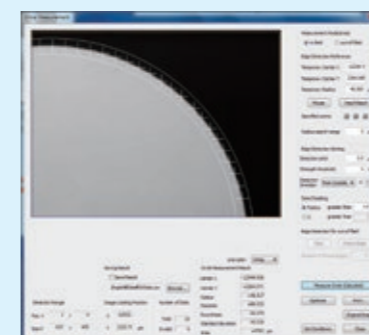

### Pattern matching

Pattern matching registers and detects alignment markers, various patterns as model images. Also, it measures the inclination of the workpiece from the center of gravity of the detected patterns and automatically detects measurement position. This function is effective for extracting the target patterns from images with low gradation and irregular luminance.

[Application] Position displacement measurement of an optical element package.

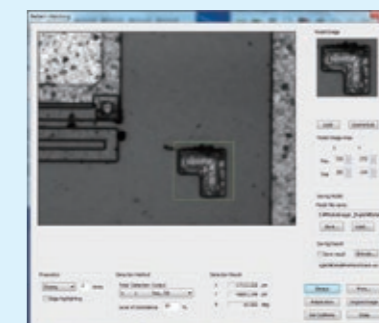

\*with scale marks of the standard scale

## Microlens array form measuring and optical characteristic evaluation instrument

### NH-3MAs

High precision image processing offers optical characteristics evaluations

Functions

- Effective focal length
- Back focus
- Transmittance
- Focal position
- Focal depth
- MTF

Automatically measures microlens arrays (MLA)

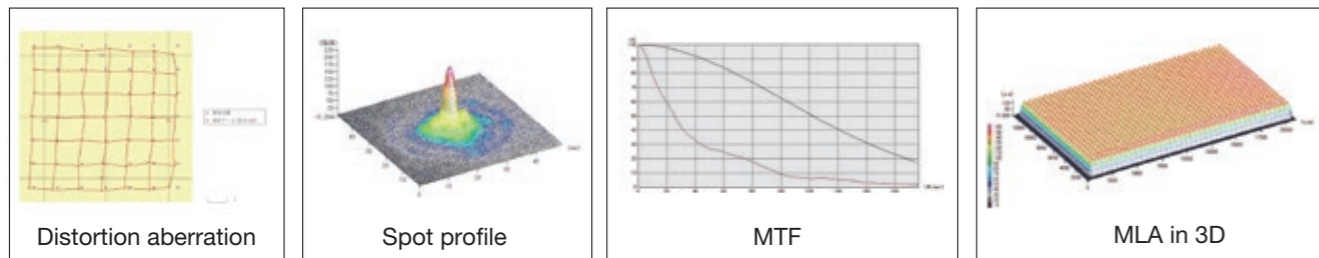

The right figure shows the measurement optical system. The focused image (the pinhole slit image) of the parallel laser beam is enlarged by the microscope lens and is captured by the CCD camera. The image processing evaluates this captured image on its optical characteristics. The specialized matrix measurement software offers automatic measurement of MLA by registering the array patterns.

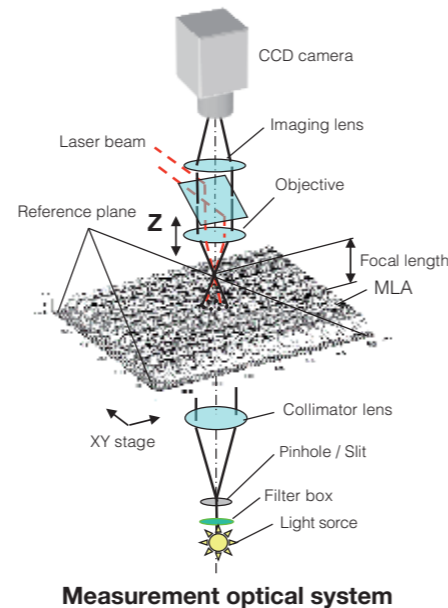

Measurement example

- MLA for LCD projector
- MLA and molds for optical communication systems
- Fly eye lens and molds
- Rod lens arrays
- CCD on chip lens
- Planar microlens for optical integrated circuit

### How to create Matrix measurement

Enter pitch / enter measurement point

Load pattern

Confirm measurement position (matrix)

Additional customization: Remove unnecessary parts, special arrangement, etc.

Save pattern

Start measurement

Automatically measure and evaluate optical characteristics

## Nomarski interference contrast observation

NH microscope can load Nomarski interference contrast optical system. Nomarski optical system visualizes angstrom-level surface roughness and scratches that normal bright-field optical systems cannot visualize, and offers immediate quantitative measurements of roughness and step heights.

Ray diagram of NH Series with Nomarski optical system

	Central part	Periphery
BF reflected light illumination image		
Nomarski image		

NH-3Ns loaded with Nomarski optical system

## Custom-made modules

Mitaka offers perfect solutions for special needs

### Thermostatic chamber

High precision measurement of a workpiece surface deformed by temperature change

NH Series offers quantitative analysis of thermal deformation of a workpiece surface in micrometer level by simply adding the precision thermostatic chamber (ceramic heater type / air heater type) on to its base plate. The thermostatic chamber continues to be active and well accepted in heat distortion measurement of precision pressed parts, environmental test of electronic components and various research fields.

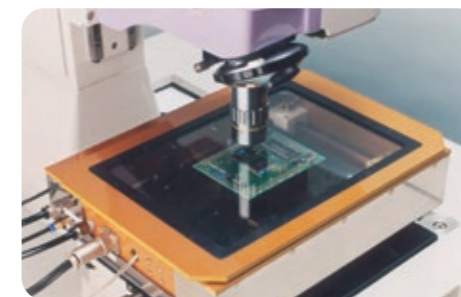

Thermostatic chamber (ceramic heater type)

● Applications

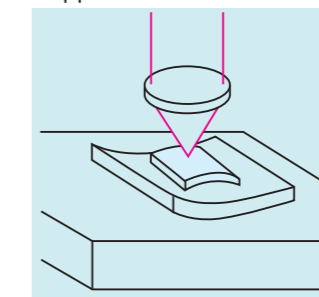

Warpage of a semiconductor device due to thermal stress

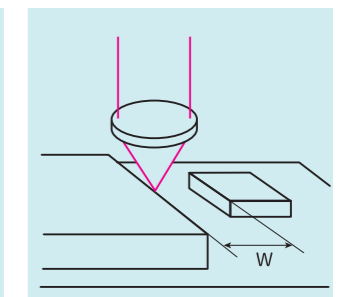

Size measurement of a surface mounting component under high temperature environment

## Custom-made stages

### Wafer holder

Precision wafer holder (air chuck type) specially designed for NH Series



### Automatic $\theta$ stage

Enhances the operability of measurement and offers easy setup of workpieces



### Porous vacuum stage

Snugly holds thin and delicate workpieces (i.e. thin film)

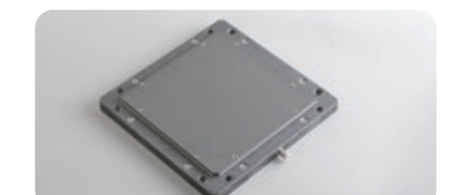

# 3D Surface Texture Analysis Software

## MitakaMap

Interactive and user-friendly software complete with powerful online help. Advanced analysis is carried out by applying straightforward operations to measurement data.

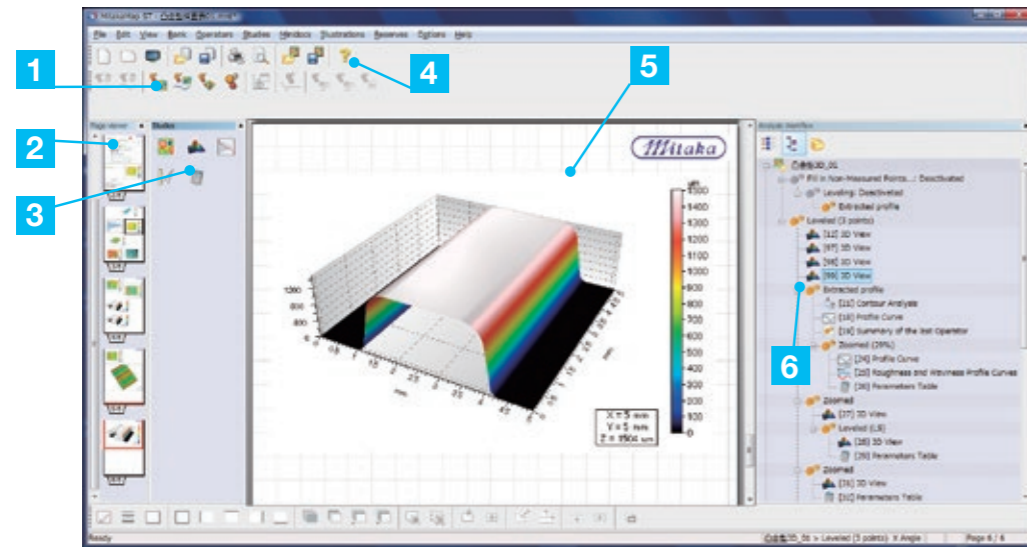

- 1 Minidocs**  
Automatic analysis by insertion of pre-defined sequences of analysis steps
- 2 Page viewer**  
Fast navigation to every page in the analysis report
- 3 Studies**  
Icons for analytical studies applicable to the selected data set
- 4 Online help**  
Detailed descriptions of all studies and operators
- 5 Document page**  
Current page in the analysis report
- 6 Analysis workflow**  
Tree view of all analysis steps in the report

## Advanced Contour Module

Additional operators and studies for Contour Analysis (standard) and Advanced Contour Analysis (optional module) provide powerful dimensional and form deviation analysis

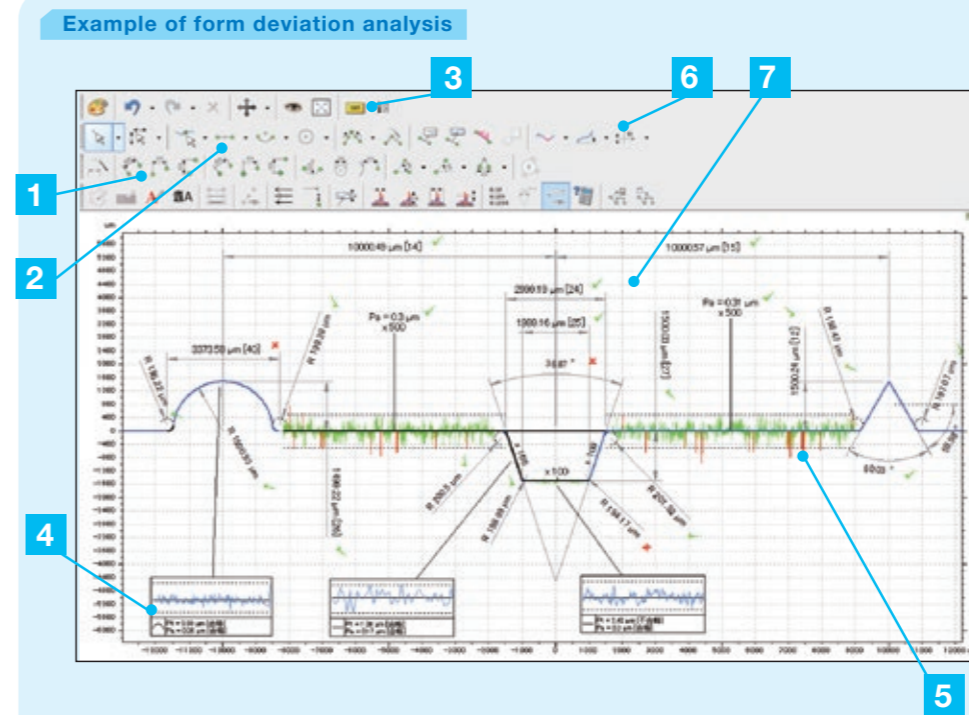

- 1 Analysis tools**  
Tools for width, distance, height, radius, diameter, angle of intersection, horizontal angle, angle of an arc, etc.
- 2 Creating segments**  
Associating segments (lines and arcs) with a measured profile for dimensional analysis
- 3 DXF input**  
Loading CAD data (DXF) in order to compare the measured profile with design specifications
- 4 Residue tool**  
Graphical study of form deviations of straight lines and arcs (Pz, Pa, Pq, etc..)
- 5 Deviation tool**  
Viewing magnified form deviation graphics and highlighting out of tolerance data points in red
- 6 Coordinate conversion tools**  
Changing leveling position and the origin
- 7 Analysis window**  
Analysis space for scaling a profile, positioning dimension lines and numeric results

### 2D surface texture analysis

- Primary profile (P-parameter)
- Roughness (R-parameter)
- Waviness (W-parameter)

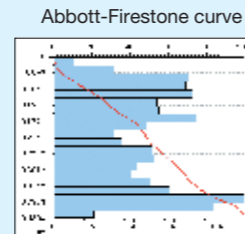
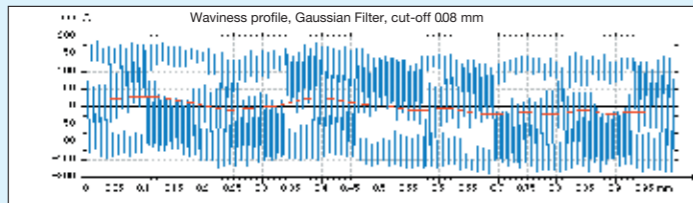

Result: Roughness:  $Ra = 0.102$ ,  $Rz = 0.331$ ,  $Rsm = 10.0$  ( $\mu m$ ) Waviness:  $Wz = 0.041$  ( $\mu m$ )

- Extensive filter types
- Gaussian filter
  - Double Gaussian filter
  - Spline filter
  - Robust Gaussian filter
  - 2RC-ISO
  - 2RC-PC

#### Standard parameter

- (ISO 4278/JIS B 0601, ASME B46.1)
- Height (peak and valley)  $Rz, Ra, Rp, Rv, Rc, Rq, Rsk, Rsq$
  - Spacing:  $Rsm, Rdq$
  - Material ratio:  $Rmr, Rdc$
  - Peak:  $Ppc$

### Profile analysis

#### Contour analysis

Automatic calculation of width, height, curvature and distance. The tolerance limit function is a perfect solution for quality control of precision parts.

Vee-groove analysis

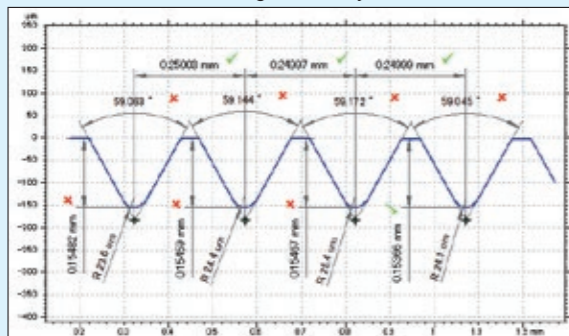

### Areal surface texture analysis

Parameters defined in ISO 25178 are pre-installed.

#### Standard parameters

- Height:  $Sz, Sa, Sp, Sv, Sq, Ssk, Sku$ , ISO 4278-2, ASME B46.1, EUR15178N
- Flatness:  $FLT, FLTp, FLTV, FLTq$  (ISO 12781)

Surface after electrical discharge machining (laser spot radius  $R = 0.5 \mu m$ )

ISO 25178 Height Parameters

Sz	3.2665 $\mu m$
Sa	0.2167 $\mu m$
Sq	0.2779 $\mu m$
Ssk	0.6995
Sku	5.6783

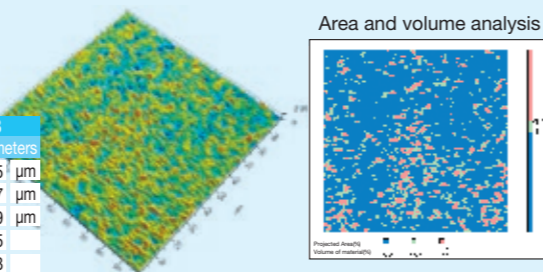

## Motifs Analysis

Dividing surface asperity into ridge and course lines in order to extract local peaks and pits for detailed surface observations

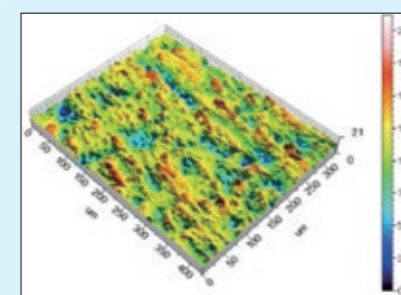

#### Visualization of motifs

Dividing peaks by course lines

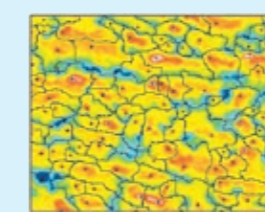

#### Batch output of analysis result

Numbering all motifs and exporting the full set of numerical results to a text file

#### Individual analysis

Visualizing an individual motif and generating its specific parameters

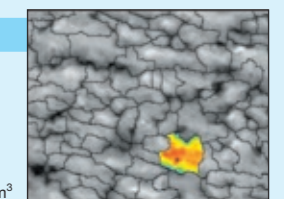

#### [Motif Parameters (Typical parameters)]

- Number of motifs
- Nb of neighbors
- Form factor
- Type of Motif
- Pitch (max/min/mean)
- Aspect ratio
- Height
- Coflatness
- Roundness
- Area
- Perimeter
- Compactness
- Volume
- Mean diameter (max/min/mean)
- Orientation
- Sphere radius
- Extremum of XYZ

Height: 2.02  $\mu m$   
Area: 0.004  $mm^2$   
Volume: 867.8  $\mu m^3$

## [Standard]

Specifications		Model	NH-3SPs	NH-3Ns	NH-4Ns	NH-5Ns	NH-3MAs	
Microscope	Observation optical system		Infinity-corrected (f = 180 mm)	Infinity-corrected (f = 100 mm)	Infinity-corrected (f = 100 mm)	Infinity-corrected (f = 180 mm)	Infinity-corrected (f = 180 mm)	
	Objective lens		10 × (NA = 0.3, WD = 11 mm)	20 × (NA = 0.4, WD = 12 mm)	50 × (NA = 0.5, WD = 10.6 mm)	100 × (NA = 0.8, WD = 3.4 mm)		
	Revolving nosepiece		Motorized quintuple					
	CCD camera		380,000-pixel color CCD camera (optional: 1,450,000-pixel color CCD camera, black/white CCD camera, etc.)					
	Illumination		BF Reflected light illumination device					
Measuring range	X		150 mm	150 mm	250 mm	300 mm	100 mm	
	Y		150 mm	150 mm	200 mm	400 mm	100 mm	
	Z		120 mm	100 mm	100 mm	120 mm	100 mm	
	AF*1		10 mm (optional: 15 mm, 20 mm)					
Positioning resolution	X		0.01 μm			0.1 μm		
	Y		0.01 μm			0.1 μm		
	Z1 (AF)		0.001 μm			0.01 μm		
	Z2 (Positioning)		0.1 μm					
Accuracy (L=length(mm))	X, Y scales		(0.5 + 2.5L / 1000) μm		(2 + 4L / 1000) μm			
	Z1 (AF) scale		(0.1 + 0.3L / 10) μm		(0.3 + 0.5L / 10) μm			
	Z2 (Positioning) no scale		(3 + L / 10) μm					
	Z2 (Positioning) with scale		(1 + 2L / 120) μm	(2 + 3L / 100) μm	(2 + 3L / 100) μm	(2 + 3L / 120) μm	(2 + 3L / 100) μm	
Measurement repeatability (AF)		σ = 0.01 μm		σ = 0.03 μm				
Autofocus	Laser spot diameter		100 ×: approx. 1 μm	50 ×: approx. 2 μm	20 ×: approx. 4 μm	10 ×: approx. 15 μm		
	Laser		Semiconductor laser O/P: 1 mW (MAX) Wavelength: 635 nm Class 2 IEC 60825-1:2014					
Other	Base plate size (W × D)		284 × 240 mm	244 × 240 mm	364 × 244 mm	400 × 480 mm	244 × 240 mm	
	Max. workpiece height		125 mm	105 mm	105 mm	120 mm	105 mm	
	Max. workpiece weight		12 kg			100 kg	12 kg	
	Instrument size (W × D × H)*2		1550 × 920 × 1610 mm	1550 × 900 × 1400 mm	1660 × 970 × 1400 mm	2100 × 1420 × 1720 mm	1550 × 900 × 1400 mm	
	Instrument weight		320 kg	210 kg	250 kg	1500 kg	220 kg	
	Power consumption		700W(100V7A)			1 kW (100V10A)	700 W (100V7A)	
Special vibration isolator		Air spring (pressure supply: 5 kgf / cm <sup>2</sup> )						
Control unit		XY scanning stage control unit, control computer, PC rack						
Standard software		Alignment function, reference plane creation function, height measurement, 2D / 3D measurements and evaluation, roughness measurement, point measurement, 2D size evaluation, teaching macro function (creation and execution), image capture (380,000-pixel)						

## [Options] Separate consultations are required

Specifications		Model	NH-3Ns	NH-3MAs	NH-3SPs	NH-4Ns	NH-5Ns
Hardware	Transmission stage and light device		○	●	○	○	—
	Rotation stage		○	○	○	○	○
Safety measures	Thermostatic cover		○	○	●	○	○
	Emergency stop button		○	○	●	○	●
	Interlock mechanism		○	○	○	○	○
Software	Aspherical form evaluation		○	○	○	○	○
	Optical flat correction		○	○	●	○	○
	Optical characteristic evaluation		○*3	●	○*3	○	—
	Image processing (Mitaka Imager)*4		○	●380,000 pixel	○	○	○
Special software		Vector evaluation, 3D dividing evaluation, matrix measurement, flyeye lens measurement, 3D mask measurement, drawing print-out, BAR creation, form deviation evaluation, coplanarity evaluation, image evaluation (SurgtopEye / WinROOF / DynamicEye), MitakaMap, focus depth measurement*5 MTF evaluation*5					
Other		Objective lenses (5×, 50×: NA = 0.35, W.D. = 18 mm, 100×: NA = 0.95 W.D. = 0.35 mm, etc.), wafer holder, 6-inch automatic θ stage, magnification optical system (f = 180 mm), Nomarski optics, thermostatic chamber, infrared transmission observation, printer					

\*1 AF in the above table refers to "autofocus" axis. AF axis has a linear scale.  
 \*2 Instrument size includes the PC rack.  
 \*3 Transmission stage and light device / 380,000-pixel image processing software are necessary.  
 \*4 Either 380,000-pixel / 1,450,000-pixel must be selected for Mitaka Imager (Imaging processing software). (Different CCD camera for different pixels) (Image capture software is included as standard software)  
 \*5 The special software for NH-3MAs and optical characteristic evaluation.

## Outline drawing Unit: mm

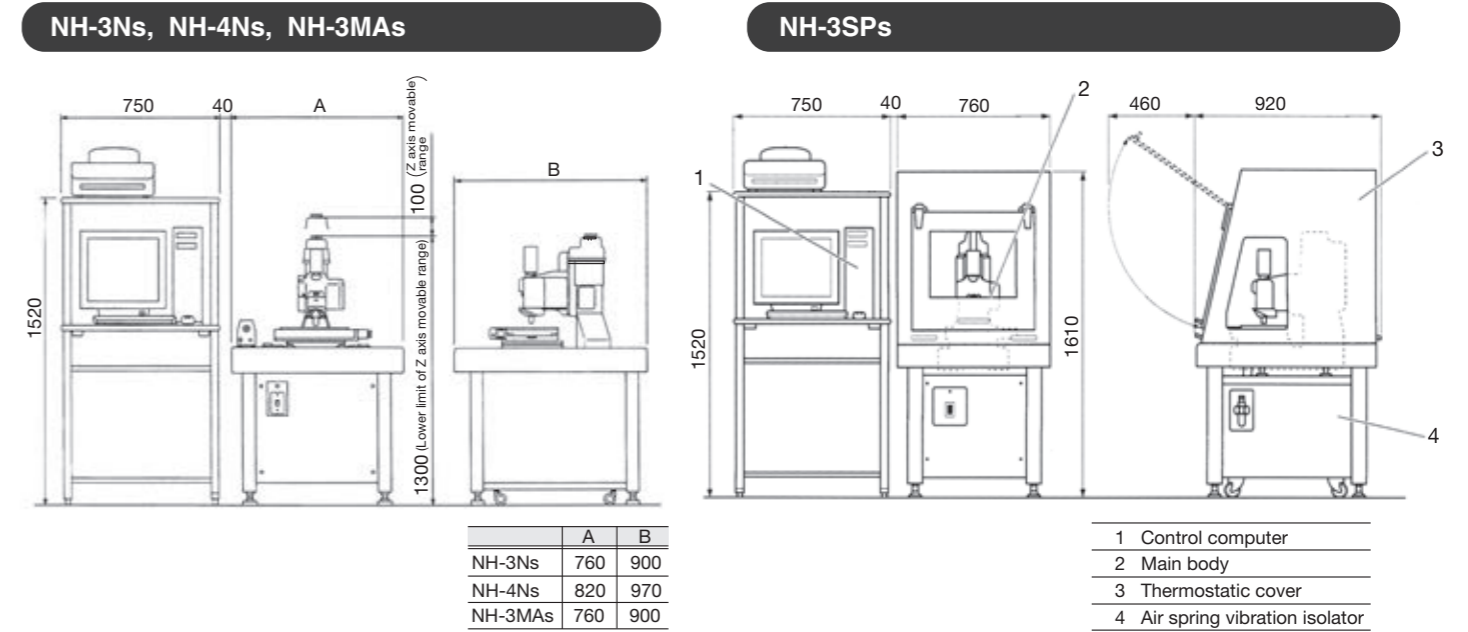

## NH-5Ns

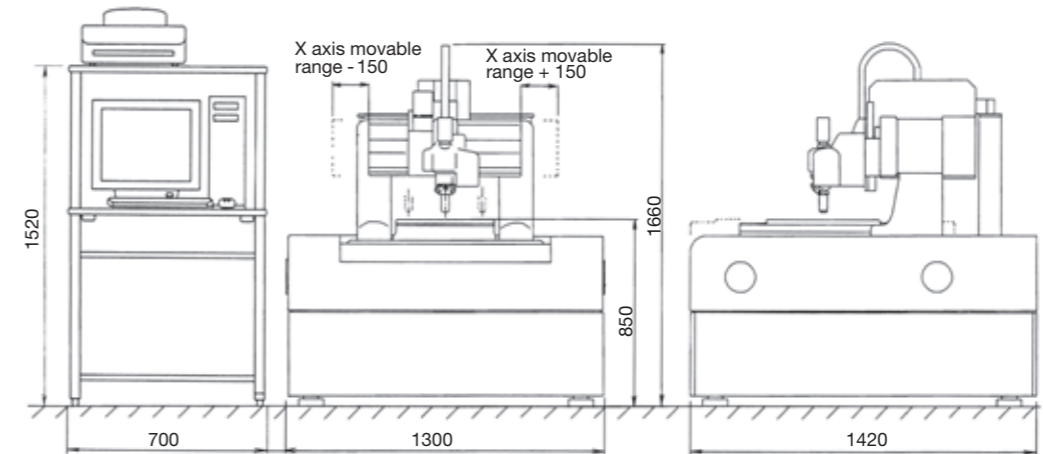

## NH-3Ns · System diagram

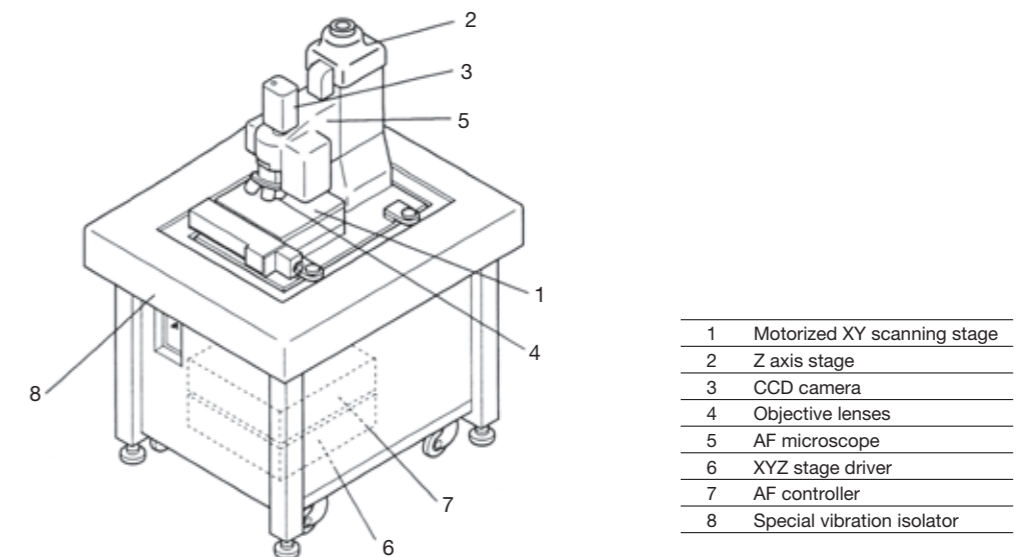

# Mitaka



For information only.  
Specifications subject to change without prior notice.

Distributor

**MITAKA KOHKI CO., LTD.**

1-18-8 Nozaki, Mitakashi, Tokyo 181-0014 Japan  
TEL +81(0)422-49-1491 FAX +81(0)422-49-1117  
<http://www.mitakakohki.co.jp>  
E-mail: [sales@mitakakohki.co.jp](mailto:sales@mitakakohki.co.jp)

**2M TRADING**

2M TRADING EOOD  
2emtrading.com  
info@2emtrading.com  
Nadezhda District,  
10 Petko D. Petkov str.,  
entr. A, ap. 24, 1231  
Sofia, Bulgaria

+359 88 740-2046  
+359 88 252-1705

