

*The entire world of
fixturing systems*

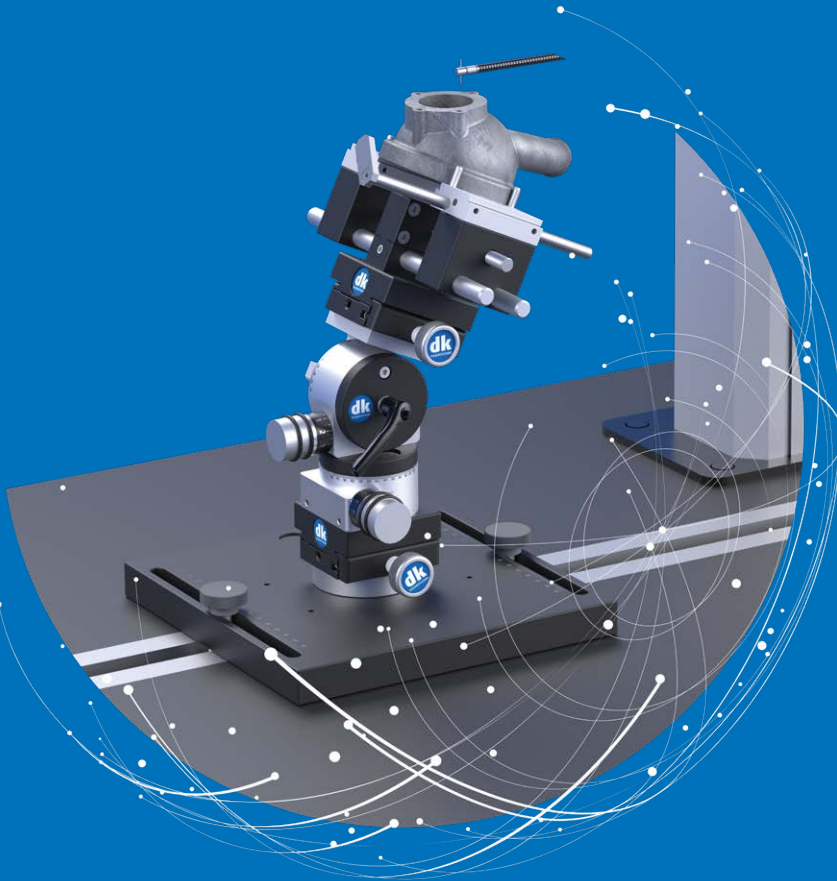

TACTILE MEASUREMENT



OPTICAL MEASUREMENT



MACHINE VISION & SENSOR



SURFACE & CONTOUR MEASUREMENT



COMPUTED TOMOGRAPHY



LASER METROLOGY SYSTEMS



Modular clamping systems for all application fields in measurement, testing and laser technology as well as for machine vision and sensor technology.

The complete dk system consists of several differently orientated but mutually compatible ranges. We also develop customer-specific solutions. Our aim is to bring the part being tested into the optimum position and to hold it there with the least possible clamping force and highest degree of repeat accuracy. This applies to both one-time part clamping and repetitive measuring tasks. The most professional solutions include the use of modular clamping systems. Single elements can be accurately and with high repeatability constructed to form

constantly new fixture combinations. The CAD models available from dk support the planning of measuring fixtures as well as their documentation.

» **Modular clamping systems guarantee speed, economy, conservation of resources and reliable measuring results.**

Summary of the product range

SWA39



SWA39 CT



SWA39 SURF



SCHIENENFIX



DIGITAL SYSTEMS

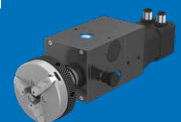

SPANNFIX ECO

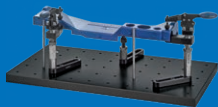

SPANNFIX PRO

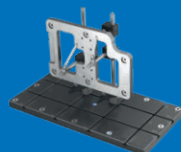

QUADERFIX

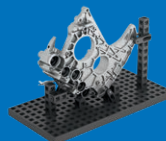

MICROFIX



NADELFIX



ARTICULAR SYSTEMS



MACHINE VISION



CONCENTRICITY



SCANNING

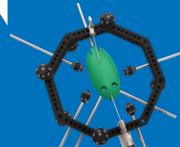

SPEZIALFIX

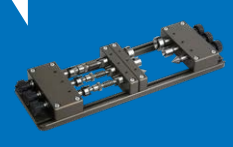

Advantages of the dk products

» Rapid assembly

The perfectly matched module elements enable complete clamping fixtures to be easily constructed and workpieces quickly clamped.

» Accessible measuring points

Best possible accessibility of the workpiece to be measured, reaching as many measuring points as possible in one clamping.

» Secure measuring

Parts to be measured are held in a stable position. Measurement results are not falsified. Measuring processes occur without interference.

» Low fixture costs

The intelligent dk concept, with a wide selection of standard modules, enables the construction of simple or complex clamping fixtures without the need of machining special parts. The constructions can be repeatedly taken apart and re-assembled in a new configuration. High wear resistance guarantees many years of repeated use. That sustainably reduces processing times by new products and consequently saves fixture costs.

» Reproducible setups

After the first measuring process, further workpieces can always be located in the same position. Repeat measurements can be carried out in automatic mode, thereby reducing measuring time.

» Combinable systems

The scope of the modular system and the choice of configurations of the individual modules enable solutions to be produced for virtually any clamping task or measuring process. The mutual compatibility of the different dk product ranges facilitates further combinations in the future.

SWA39

Quick-change complete system for tactile and optical measuring

- » For zero-point clamping of fixtures
- » Basic elements for adaptation to metrology machines
- » Structural elements for free 3D spatial positioning
- » Clamping elements for all categories in many types and sizes
- » With stops for accurate repeat positioning of test parts
- » With scales for exact reproduction of complete fixtures
- » Also for laser scans, digital systems, multi-sensorial systems or as basis for CT fixating systems



SWA39 CT

Clamping systems for computed tomography

- » Professional system modules based on the SWA39 standard programme
- » Universally applicable for all test specimen sizes, geometries and materials
- » Resource saving and efficient through simple, rapid, secure and repetitively accurate fixture construction
- » X-ray transparent modules as CT-suitable holders for metallic workpieces; hybrid modules with additional moulded foam elements for plastic test specimens
- » Functional holders for small and micro parts as well as multi-tower for efficient measurement of large batches of test specimens simultaneously



SWA39 SURF

Clamping systems for surface and contour measurements

- » Exactly adaptable to processes through function and size variants as well as accessories
- » Precision 3D spatial adjustment through infinitely variable linear, rotary and tilt elements with scales for simple, accurate and reproducible adjustment of the overall fixture
- » Simple and rapid measurement set-ups due to dk quick-change interfaces
- » Minimisation of clamping forces for filigree parts: controlled, adjustable and reproducible
- » Universal utilisation together with other fields of quality assurance and also for laser marking through standardised SWA interfaces

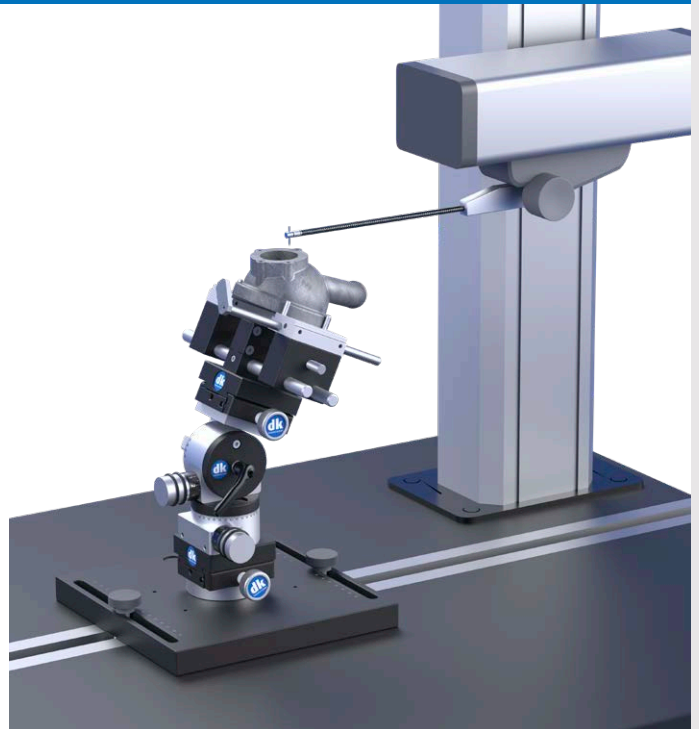

SCHIENENFIX

Clamping system for optical and multi-sensorial measuring

- » Universal application through resource-saving modularity and diversity of the components
- » Optimum visibility in incident and transmitted light due to serrations instead of smooth edges
- » Toothed rails as workpiece rests or for fastening add-on and clamping modules
- » Maximum economy due to real time setups separate from the measuring machine using a quick-change pallet system
- » For optical-tactile machines, measuring projectors and microscopes
- » Compatible with SWA39 and other dk programmes

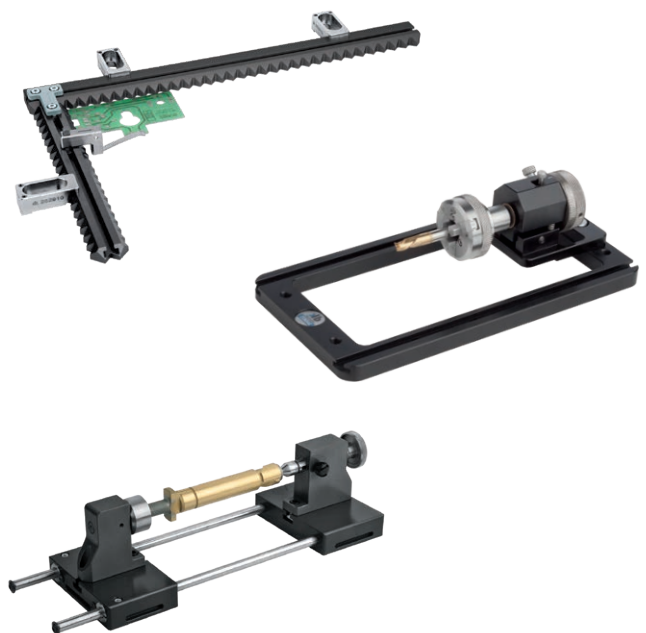

DIGITAL POSITIONING SYSTEMS

Dividing head / tailstock with motor control

- » Efficient processes through motorised dividing heads with position feedback using an encoder
- » Perfect integration into existing controls or as a stand-alone solution

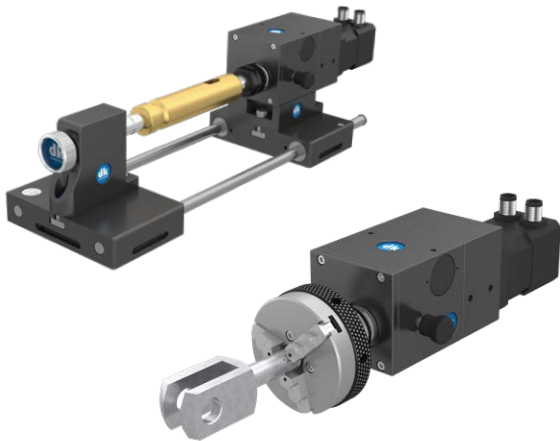

SCANNING

Clamping solutions for scanning

- » Special products for scanning with or without target points
- » For fringe projection, fringe light scanning, structured light, photogrammetry, digital image correlation and all types of structured-light 3D scanning
- » Target bases as support elements for the reference points can be combined with all dk fixation programmes



MICROFIX

Clamping solutions for micro parts

- » Suitable for the smallest parts from 0.3 mm to 10 mm
- » Gentle fixation with adjustable clamping forces
- » For rotationally symmetrical and cubic test pieces



NADELFIX

Needle support

- » For variable moulding to products
- » Ideal for holding free-form parts using positive fit
- » Compatible with SWA39 and other dk programs

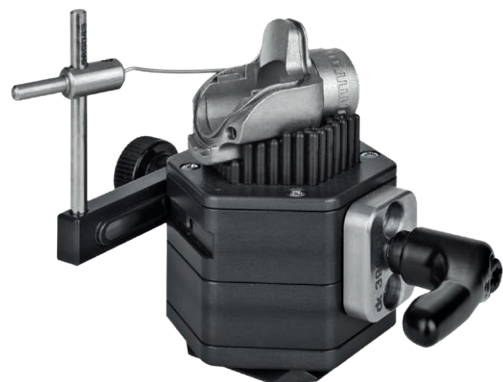

Modular clamping elements for tactile measuring

- » The basis is formed by baseplates or quick-change adapters
- » Exact reproducibility through a slot system with graduations or very economical with tapped grid holes
- » Wide range of structural and clamping elements
- » Flexible clamping solutions for the most varied workpiece geometries
- » Quick, easy and infinite assembly
- » With intelligent modules also suitable for the vertical fixation of workpieces to the columns
- » Interfaces for all dk programmes

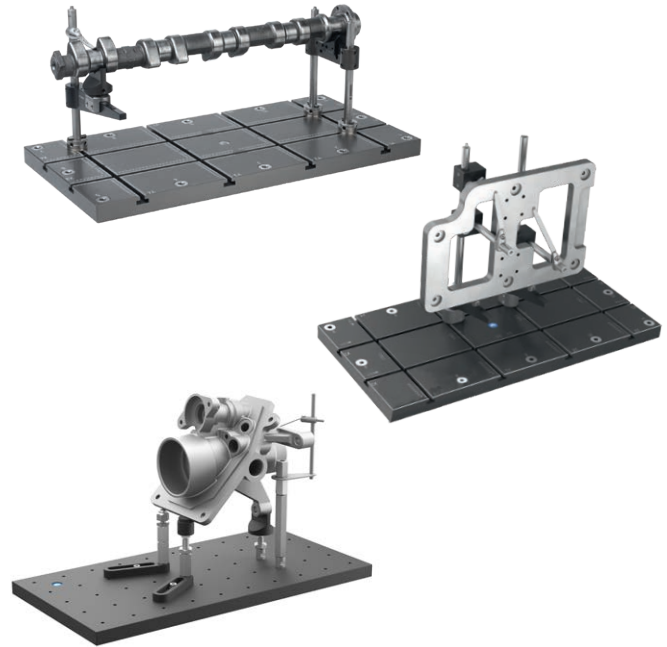

QUADERFIX

Clamping system for tactile measuring – cuboid elements

- » Modular fixture system constructed from standard cuboid elements
- » Drilled through holes on a 25 mm grid
- » Torsion-proof connection of the modules through positive locking of the contact elements
- » For fixating large and heavy parts with arbitrary support points in XYZ axis
- » Fully 3-dimensional configuration to access all 3D spatial positions
- » Also as a basis for laser scanning and quick-change pallets for real-time parallel set-ups
- » Compatible with the SPANNFIX programs

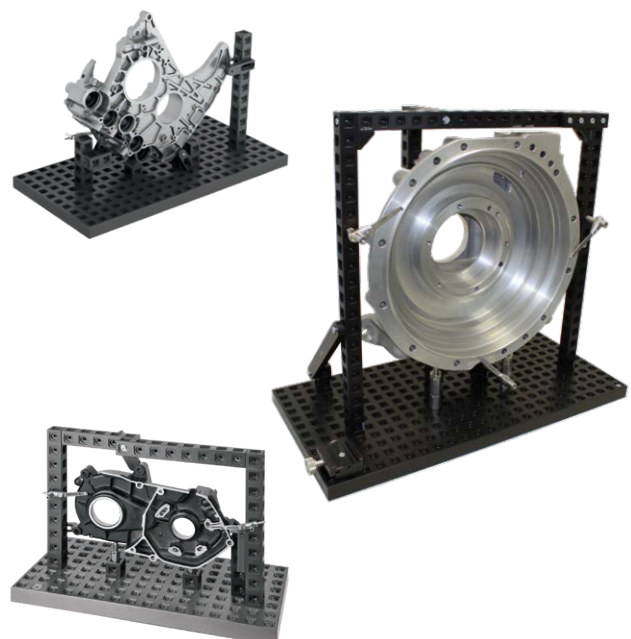

Gauge stands, 3D articulated joints and radial run-out testing fixtures

- » Five programmes for maximum 3D flexibility by measuring, positioning and for machine vision
- » Rust-free and sterilisable types for cleanrooms
- » Perfect radial run-out testing with tolerance-free support and intelligent stop positioning
- » Modular design for use together with the other dk programmes

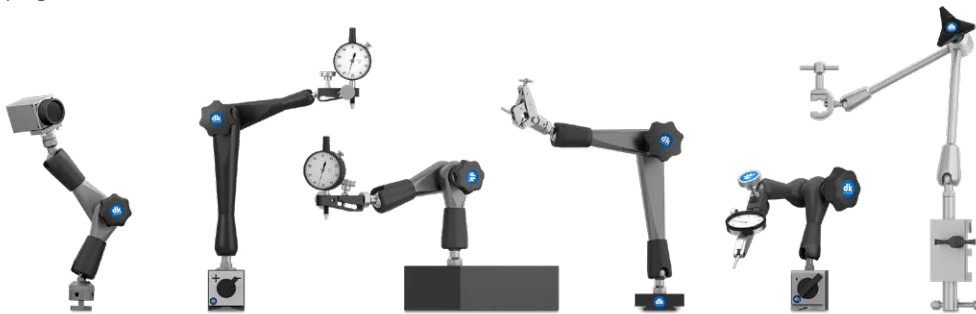
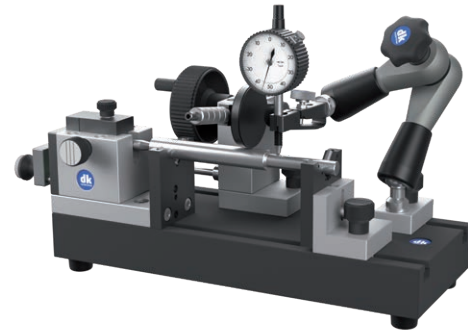

SPEZIALFIX

MACHINE VISION

Customised clamping fixtures

- » We develop, design and manufacture special clamping fixtures according to your specifications
- » Simple to complex multiple clamping fixtures with mechanical, pneumatic, electro-mechanical or combined fixating, clamping and handling components

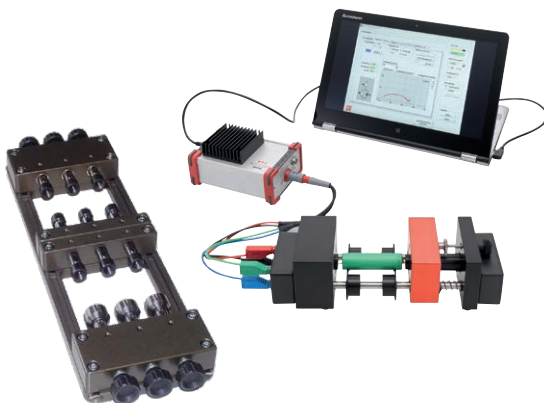

3D articulated arms for machine vision

- » Mounting programme for machine vision, image processing and sensor technology
- » For cameras, sensors, end-of-arm robotic tools, illumination etc.
- » Five programmes for every imaginable requirement
- » Extensive range of fastening elements, camera brackets and equipment plates





The digital version of the catalogue can be found under:
www.dk-fixiersysteme.de



dk FIXIERSYSTEME GmbH & Co. KG
Ferdinand-Lassalle-Strasse 35
D-72770 Reutlingen, Germany

Tel. +49 (0) 7121 90 97 10
Fax +49 (0) 7121 90 97 120
info@dk-fixiersysteme.de
www.dk-fixiersysteme.de

modular. simple. better.

TRADING

2M TRADING EOOD
2emtrading.com +359 88 740-2046
info@2emtrading.com +359 88 252-1705
Nadezhda District,
10 Petko D. Petkov str.,
entr. A, ap. 24, 1231
Sofia, Bulgaria



The entire world of fixating, clamping and positioning

The around 1,000 part comprehensive standard construction sets of the dk fixating systems for measuring technology offer the following advantages:

- » Modular system that has grown and proven itself over decades
- » Modularity across different programmes
- » Solutions for every positioning task
- » Economic efficiency through the synergy effects of several sector solutions



**FAST
REASSEMBLY
LIFELONG**

The basic principle of all dk fixating systems!

Our fixtures are modular in design, can be dismantled at any time and can be identically reassembled again. The compatibility of the dk fixation systems makes the utility value perfect.